

## CCD Line Scan Camera Digital b/w SK 1024 XSD

1024 Pixels, 14 x 14 µm, 20 MHz Pixel Frequency

Camera Family XSD 512 1024 2048

- 1 CCD line scan camera SK 1024 XSD mounted on
- 2 Camera mount SK5105
- 3 Clamp set SK5102
- 4 Video(CCTV) lens



### Charakteristics

- digital camera 8 Bit (optional 12 Bit)
- high dynamics
- high line frequency up to 18.4 kHz
- anti blooming
- integration control
- gain/offset programmable
- very low noise
- light sensitive
- CDS technology
- round housing Ø 65 mm

### Accessoires (optional)

**Camera mount SK 5105** (Order Code)  
Wrap resistant construction for the mounting of the CCD line scan camera. Optional: Clamp set SK 5102 (Order code) to lock the CCD line scan camera in arbitrary rotation.



**Mounting console SK 5105-2**  
for adaptation of macro lens, extension ring ZR..., focus adapter FA22-C and the CCD- line scan camera



### Lenses

- high resolution **Enlarging lenses and macro lenses**
- high speed **photo lenses**
- lenses with additional **blocking bridge** for locking of focus and aperture setting.



### Adapter

- Lens adapter AOC-...** for adapting photo lenses onto the CCD line scan camera
- Focus adapter FA22-...** für adapting Enlarging lenses and macro lenses.



**Connecting cable SK9019 for Digital CCD Line Scan Cameras** of Camera Series XSD, DPD, DPT, DJR, DJRC etc.  
36-pin shielded cabel for camera and video signals. Standard: 3m cabel length, one- or double-sided with Centronics connectors (female, 36-pin).



**SK9019.3 FF** Order Code

- FF = Connector double-sided (female)
- F = Connector one-sided (female)
- 3 = 3 m (standard cabel length)
- 5 = 5 m cabel length
- x = Cabel length custom made

**PC-Interface SK 9192 D** Order Code  
Interface for digital CCD Line Scan Cameras. **PCI-Bus**, preprocessing on-board: shading correction, windowing, thresholding external synchronisation (LineSync, FrameSync)



**Software SK91PCI-WIN \* SK91PCI-LX \*\***  
System Software, Drivers, DLLs, \* Windows, \*\* Linux



### Performance Specifications

Camera Type: SK 1024 XSD

#### Order Code

**Physical Characteristics**  
Sensor: CCD linear  
Type IL-P3-1024B  
Pixel Number: 1024  
Pixel Size: 14 µm x 14 µm  
Pixel Distance: 14 µm  
Line Width: 14 µm  
Active Length: 14.3 mm

#### Operating Ranges

Pixel Frequency: maximum 20 MHz  
Line Frequency: maximum 18.4 kHz  
Integration Time: minimum 10 µs  
maximum 20 ms  
Dynamic Range: 1 : 5000 (rms)  
Spectral Range: 400 - 1000 nm

#### Typical Spectral Responsivity

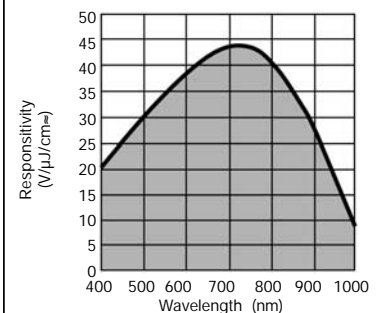

#### Input Control Signals

- Master Clock
- StartOfScan (SOS)
- Gain/Offset Control

#### Output Signals

Video Signal: 8 Bit digital  
Interface: LVDS

#### Power Supply

Voltage: +5 V, +15 V, -15 V  
Power Consumption: 1.5 W

#### Connector

Mini Centronics 36 pin-male



Opposite connector: Series Harting Bellows  
Typ: 6013 036 5100

#### Others:

Operating Temp.: + 5°C ... + 45 °  
Size: Ø 65mm x 50mm  
Weight: 0.2 kg  
Lens Thread: C-Mount

### Content

Content	Page	Page
Characteristics, Performance, optional Accessories	1	5
1. Technical Specifications of the XSD Camera Series	2	6
2. Handling Details of the Line Scan Camera	2	7
3. Connecting and Control Signals	3	8
Pin-out and Voltage supply	3	9
4. Exposure and Integration Control	4	10
5. Generating an Image – Scan a Surface	4	11
6. Timing Diagram	5	
7. Anti Blooming	6	
8. Gain / Offset Settings	7	
9. Dimension Diagrams	8	
10. Sensor Data	9	
11. References, Warranty and EC-Declaration of Conformity	10	

SK\_1024\_XSD\_E

## 1. Technical Specifications of the XSD Camera Series

Camera Model	SK 512 XSD	SK 1024 XSD	SK 2048 XSD
CCD sensor	IL-P3-512B	IL-P3-1024B	IL-P3-2048B
Number of pixels	512	1024	2048
Pixel size	14µm x 14µm	14µm x 14µm	14µm x 14µm
Sensor width	14 µm	14 µm	14 µm
Pixel distance	14 µm	14 µm	14 µm
Active length	7.17 mm	14.3 mm	28.7 mm
PRNU <i>Photo Response Non Uniformity</i>	3)	3)	3)
Anti-Blooming	yes	yes	yes
Integration Control	yes	yes	yes
CDS <sup>1)</sup>	yes	yes	yes
Pixel frequency max	20 MHz	20 MHz	20 MHz
Min. integration time	10 µs	10 µs	10 µs
Max. integration time	20 ms <sup>2)</sup>	20 ms <sup>2)</sup>	20 ms <sup>2)</sup>
Max. line frequency	34.7 kHz	18.4 kHz	9.5 kHz
Min. line frequency	0.05 kHz	0.05 kHz	0.05 kHz
Dynamic range	1 : 5000 (rms)	1 : 5000 (rms)	1 : 5000 (rms)
Spectral range	400 - 1000 nm 100%	400 - 1000 nm 100%	400 - 1000 nm 100%
Video signal	8 Bit digital	8 Bit digital	8 Bit digital
Interface	LVDS	LVDS	LVDS
Voltage supply	+5V, +15V, -15V	+5V, +15V, -15V	+5V, +15V, -15V
Power consumption	1.5W	1.5W	1.5W
Lens connection	C-Mount 1"-32TPI	C-Mount 1"-32TPI	M40 x 0,75
Housing (W x H x D)	Ø65mm x 50mm	Ø65mm x 50mm	Ø65mm x 51mm
Weight	0.2 kg	0.2 kg	0.2 kg
Temperature range	+5°C ... +45°C	+5°C ... +45°C	+5°C ... +45°C

1) CDS = Correlated Double Sampling. Noise reduction technology, increase of photosensitivity.

2) Longer exposure times are possible, but the signal-to-noise ratio will be reduced.

3) For further sensor specifications obtain the details of the sensor manufacturer. See the datasheet at the end.

## 2. Handling details of the line scan camera

Attention:

Before the line scan camera is attached to or detached from the power supply make sure the power supply is switched off.

Otherwise, a permanent damage of the line scan camera device is risked.

To prevent damage due to heat accumulation and keep the temperature of the camera below 45°C, a sufficient air circulation around the camera housing has to be ensured.

To start operation the camera has to be connected to the necessary voltage, the MasterClock- and StartOfScan-Signals using a 36-pin Centronics Miniature Connector.

The camera is shipped aligned and set to default settings in gain and offset. Extensive modifications of the gain/offset-parameter can lead to a decrease in signal quality.

A successful application of the line scan camera is based upon a careful adjustment of the whole optical system. Attention should be paid to the arrangement of the illumination, the aperture setting, the focussing range of the lens, as well as the orientation of the sensor axis to the scanning direction.

Recommendation:

Using the **SK9192D** PC-Interface and the **SkLineScan®** software by **Schäfter+Kirchhoff** the camera is ready for operation immediately. The oscilloscopic display of the line scan camera signal including the zoom-function and the online parameter setting of the camera is a valuable tool while arranging the optical system setup. The hardware preprocessing on the Interface board (Shading Correction, Windowing, Thresholding) enables recording and evaluation with maximum line frequency. Furthermore, the comfortable methods of the class libraries for C++ support the development of user software.

### 3. Connection and Control Signals

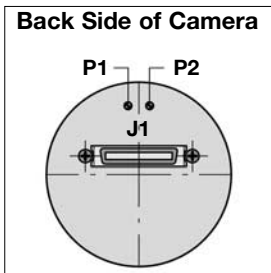

J1 = Centronics 36pin-male, P1 = Offset adjustment, P2 = Gain adjustment

#### Voltage Supply

- + 5 V ± 5% ca. 120 mA (5 MHz Clock)
- ca. 155 mA (20 MHz Clock)
- 12 V / -15 V ± 5% ca. 4 mA
- +15 V ± 5% ca. 30 mA

#### Digital Control Inputs

##### Input Control Signals:

The Low Voltage Differential input Signals (LVDS) are converted into TTL conform signals inside of the CCD camera. The camera uses only the control signals "Clock" (MCLK) and "Start Of Scan" (SOS) for operation. The camera electronic responds to the rising signal edges that should be 'sharp' and free from noise.

The frequency of the "Start of Scan" signal determines the total count of line scans per second. On the rising edge of this signal all the accumulated charges inside the pixels will be transferred to the analog shift register of the sensor. The shift register (transport register) will be read out with the 'Clock' signal.

The 'Clock' signal frequency gives the read-out rate for single pixel informations of the linear sensor. This is just the rate of the video output signal of the camera. Every rising edge of 'Clock' transfers the next following pixel's charges to the video output amplifier.

The 'Clock' and the 'SOS' signals need not to be synchronized. The 'Clock' frequency should be set to a sufficient large number to ensure enough 'Clock' pulses to read out the line sensor completely between two successive 'SOS' signals. The SK 1024 XSD-Camera needs '1024' + 39 'Clock' signals to read out a line scan completely. Generally, transferring a larger number of 'Clock' pulses as needed is unproblematic.

**MCLK:** Master-Clock in: determines the pixel transport frequency, maximum 20 MHz. Low voltage differential input.

**SOS:** Start of Scan: 30 ns minimum pulslength. Differential input.

The frequency of the 'SOS' signal determines the line frequency readout of the camera.

The charges of the sensor are accumulated while the 'SOS' signal is low. This way the length of the 'low' period can be used to effectively control the actual integration time at a fixed or rapidly changing line frequency.

The rising edge of the 'SOS' signal initiates the readout operation and the charges are transferred into the onchip analog shift register.

##### Output Signals:

'Clock' and 'Start of Scan' signals are echoed at the camera output to monitor system timings. These signals, like the input 'Clock' and 'Start of Scan' signals, are 'Low Voltage Differential signals' (LVDS).

**CCLK:** Camera-Clock out / Low Voltage Differential driver.

**LVAL:** Line Valid / Differential driver. A 'High'-level shows the availability of valid pixel data at the AD-converter output. The signal 'LVAL' contains a 'CLT' pulse at the beginning of the line, necessary to synchronize **Schäfter+Kirchhoff** - Interface boards.

**D0-D7:** 8 bit digital video output (8 x Low Voltage Differential driver LVDS) D0=LSB, D7=MSB

### Pin out

Miniature Centronics 36 pin Connector (male)						
Signal	Pin		Pin	Signal		
	GND	18	O O	36	GND	
(+5V)	VCC	17	O O	35	VCC	(+5V)
	GND	16	O O	34	D7	- out
(+5V)	VCC	15	O O	33	D7	+ out
	CCLK - out	14	O O	32	D6	- out
	CCLK + out	13	O O	31	D6	+ out
	LVAL - out	12	O O	30	D5	- out
	LVAL + out	11	O O	29	D5	+ out
	SOS - in	10	O O	28	D4	- out
	SOS + in	9	O O	27	D4	+ out
	MCLK - in	8	O O	26	D3	- out
	MCLK + in	7	O O	25	D3	+ out
	GND	6	O O	24	D2	- out
(-12V/-15V)	VEE	5	O O	23	D2	+ out
(+15V)	VDD	4	O O	22	D1	- out
(+15V)	VDD	3	O O	21	D1	+ out
	GND	2	O O	20	D0	- out
Analog Video A out (Test purpose only)		1	O O	19	D0	+ out

#### 4. Exposure and Integration Control

**Exposure:**

The light sensitive elements of the sensor store the charge which are generated by the incident light during the exposure cycle. This accumulated charge is then converted into voltage. These values are a measure for the incident light intensity on each pixel.

The process of integration starts with the falling edge of the 'StartOfScan' (SOS)-signal. While the SOS-signal is 'Low', charge is accumulated. With the rising edge of the SOS-signal the exposure is concluded. The SOS-signal level stays a short time on 'High', before the next falling edge triggers the next exposure cycle.

**Exposure time:**

The exposure time of a single line scan  $t_B$  is the time interval of adjacent positive edges of the 'StartOfScan' (SOS)-signal. The time period of this interval (pixel clock) is determined by the minimum number of necessary pulses to read the accumulated charge into the shift register of the line scan sensor.

The sum of the pixel clock pulses results from the number of pixels  $N$  plus sensor dependent passive pixel clock pulses  $N_P$ .

The camera SK 1024 XSD needs min. 1024+39 pixel clock pulses. The read out frequency is determined by the pixel frequency (MCLK). The exposure time  $t_B$  of a camera calculates:

$$t_B = \frac{(N + N_P)}{f_P}$$

The line frequency is given by:

$$f_L = 1 / t_B$$

<p><b>Example:</b></p> <p>SK 1024 XSD, SK9192D 20 MHz pixel frequency</p> <p><math>t_B = (1024 + 64) / 20 \text{ MHz}</math> <math>t_B = 54.4 \mu\text{s}</math></p> <p><math>f_L = 20 \text{ MHz} / (1024 + 64)</math> <math>f_L = 18.4 \text{ kHz}</math></p>	<p><b>Integration Ctrl:</b> SOSL= 256;</p> <p><math>t_A = ((1024+64) - 256) / 20 \text{ MHz}</math> <math>t_A = 41.6 \mu\text{s}</math></p> <p><math>t_B = 54.4 \mu\text{s},</math> <math>f_L = 18.4 \text{ kHz}</math></p>
---	---

#### 5. Generating an Image – Scan a Surface

A two-dimensional image is generated by moving the object or the camera. The direction of the movement needs to be orthogonal to the sensor axis of the CCD line scan camera.

To obtain a proportional image with correct aspect ratios a line synchronous transport and a laterally correct pixel assignment is required.

$$V_O = \frac{W_P \cdot \beta}{t_B}$$

- $V_O$  = Object rate
- $W_P$  = Pixel width
- $\beta$  = Magnification
- $t_B$  = Exposure time

- **Exposure time:** Time interval between successive "SOS" signals.
- **Integration time:** Duration of the actual charge accumulation during the exposure time.
- **Integration Control:** for CCD line scan cameras it is possible to program shorter integration times within the actual exposure time (Shutter operation).

**Integration Control:**

In the default setting of the camera the SOS signal between two exposure cycles shows 'High' only at very few pixel clock pulses. The Integration time and the exposure time are virtually of the same length.

The Integration Control function allows the extension of the 'High'-level condition in the SOS signal about a specified number of pixel clock pulses. The start of the accumulation of charge during an exposure cycle is thus delayed.

The integration time  $t_A$  is shortened to the difference of during one exposure period necessary pixel clock pulses ( $N + N_P$ ) and the specified number of clock pulses for the extension of the 'High'-level condition in the SOS signal (**SOSL**).

The line scan frequency is not influenced by the Integration Control function.

$$t_A = \frac{(N + N_P) - \text{SOSL}}{f_P}$$

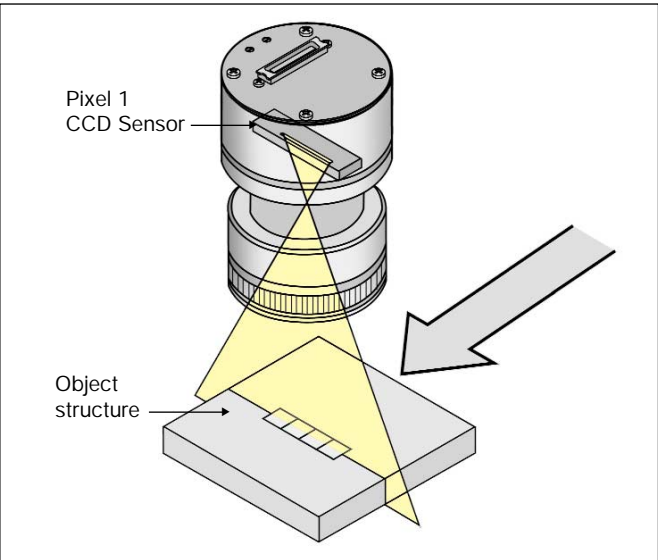
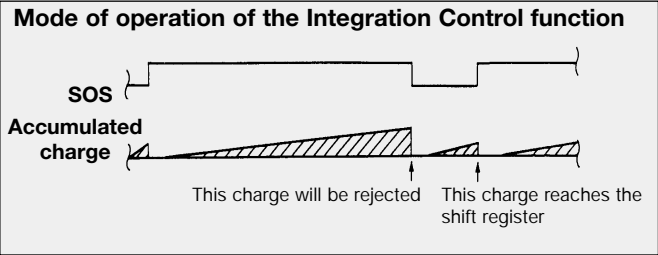

## 6. Timing Diagram

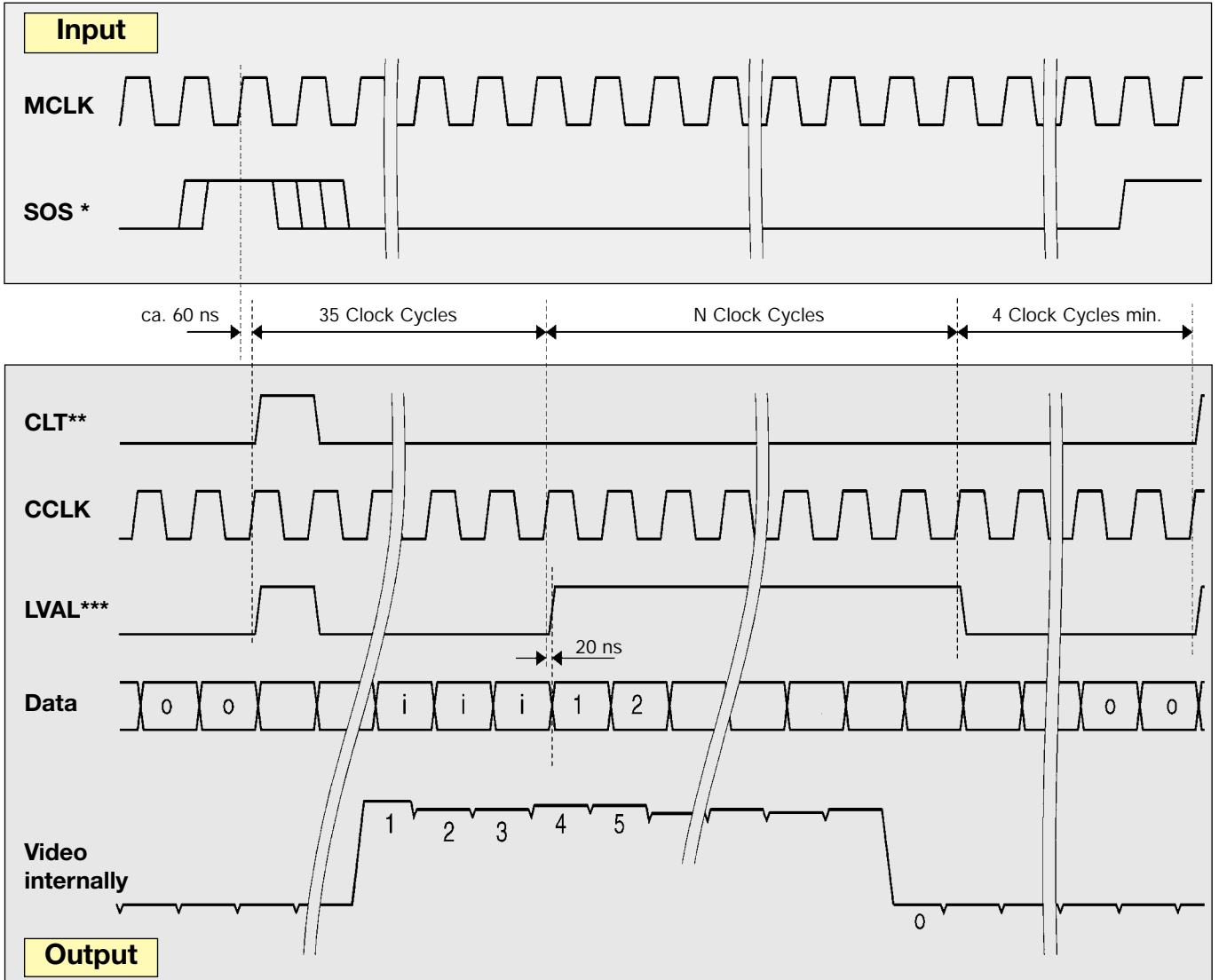

\* The rising edge of 'SOS' should not occur within a range of 3 to 25 ns before leading edge of 'MCLK'.  
(Integration Control Timing see below)

\*\* CLT = Camera Line Transfer ( internal line scan camera Signal)

\*\*\* The signal 'LVAL' contains a 'CLT' pulse at the line beginning, which is required for the synchronisation of the **Schäfter+Kirchhoff** Interface boards.

If requested, the CCD line scan camera is available without 'CLT' pulse at the line beginning of the 'LVAL'.  
Order Code SK 1024 XSD-3

The pixels determining the black level value are the 3th to the 7th before pixel no. 1.

N = Sensor pixels

i = Isolation pixels

o = Overlocking

## 7. Anti Blooming

### Blooming

Extended illumination of saturated pixels, which are not able to accumulate further charge due to long exposure, leads to charge overflow into adjacent pixels. This effect is called **blooming**. Blooming causes a corruption of the geometrical allocation of image and object in the line signal.

CCD line scan cameras with **anti-blooming** sensors direct the abundant charge to a "drain gate". Charge overflow into adjacent, less illuminated pixels is prevented. Depending on pixel frequency and spectral range, overexposure up to factor of 50 can thus be handled.

The CCD line scan cameras of the XSD-series do contain anti-blooming sensors, i.e. they are prevented from overexposure due to a special design. The Blooming Drain Gate has a limited capacity, though.

The less pixels are overexposed, the better is the anti blooming effect of the drain gate. For single pixels a charge excess of up to a factor of 50 above saturation can be drained. With increasing quantities of oversaturated pixels the charge drainage decreases.

The electronics of the XSD camera series support the blooming control possibilities of the sensor. The saturation load is regulated by the blooming control voltage  $V_A$ . The higher the voltage  $V_A$  the lower the level of anti blooming effect initiation. A high voltage  $V_A$  increases the saturation protection, but it limits the output voltage of the video signal and reduces the dynamic range of the camera. Tuning the voltage  $V_A$  to a level too small, the anti blooming effect is switched off completely. The maximum output voltage of the sensor reaches the saturation level  $V_{SAT}$ .

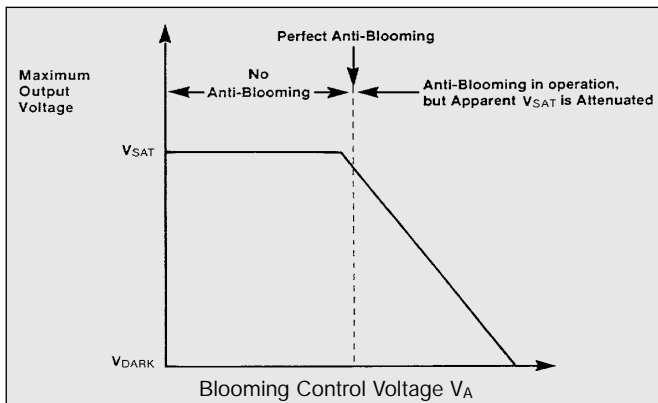

The blooming control voltage  $V_A$  is by default prepared to a level where the output voltage of the camera reaches approx. 90% of the saturation voltage  $V_{SAT}$  at maximum. Thus, an optimum anti blooming effect is ensured. **The voltage  $V_A$  should only be altered in exceptional cases.**

The anti blooming control voltage  $V_A$  is adjusted with the trimmer P3. Turning the trimmer P3 to the left, the voltage  $V_A$  rises. Turning it to the right the voltage  $V_A$  decreases. Turning it to the right bedstop, the anti blooming is switched off.

The trimmer P3 is accessed from the front of the

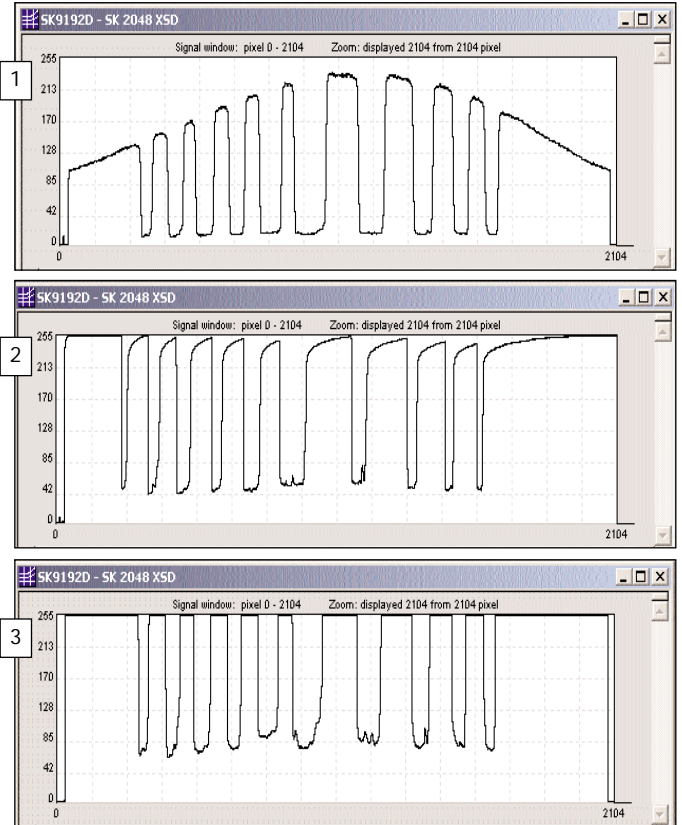

Oscilloscopic signal display of the CCD line scan signal (barcode with incident light), SK 2048 XSD

- 1 Line scan signal with central enhanced illumination and sharp rising signal edges. Integration time  $t_A = 0,158$  ms
- 2 Over exposure due to longer integration time ( $t_A = 0,533$  ms). The blooming effect is raised in the sensor by misadjusting the blooming control voltage (low  $V_A$ ). The structures of the signal are distorted.
- 3 The blooming control voltage limits the output signal of the sensor to approx. 90% of the saturation voltage  $V_{SAT}$ . The anti blooming technique is active. Also, with even longer integration time ( $t_A = 0,806$  ms) the signal edge positions from Fig. 1 are preserved.

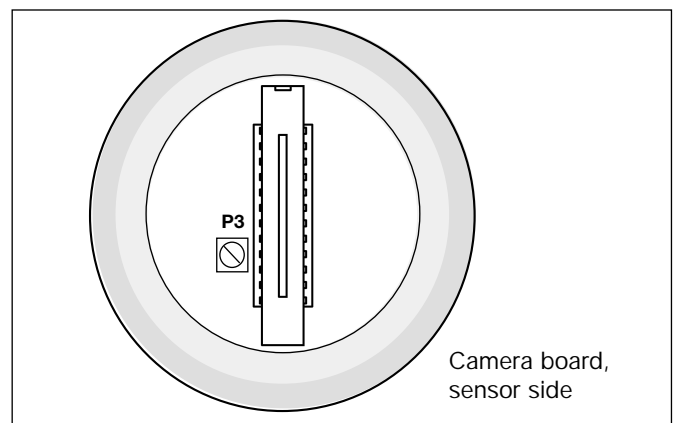

camera with the lens taken off.

To prevent misadjustment of the line scan camera, the effect of the P3 adjustment should be performed and tracked with sufficient illumination observing an oscilloscopic display of the line scan signal on the PC monitor.

## 8. Gain / Offset Settings

Gain and offset of the cameras of the XSD series can be set either by trimmer or through software.

By default the trimmer are activated. Thus, a manual gain / offset adjustment is possible.

To use the gain and offset adjustment through the software, the gain / offset control has to be activated with a command beforehand. After this, regarding the gain / offset control, the camera responds to the software commands only. In this control mode the trimmer are bypassed. Only after deactivating the gain / offset control via software the manual gain / offset control using the trimmer is possible again.

### Programming of gain / offset

The programming of gain and offset is by now only possible by using the PC interface board **SK9192D** and the software **SkLineScan®** by **Schäfter+Kirchhoff**.

The basic software program **SkLineScan®** offers a special dialog for the gain and offset setting of the XSD cameras. Changes of these settings are prompt visible in the oscilloscopic display of the line scan signal.

The programming of the XSD cameras provide an internal camera number setting between 0 and 3 by default.

Using "Camera Select" the desired camera is selected. "Enable Control" transfers the gain / offset control to the software. The gain / offset slides simplify the handling, and the setting can be easily optimized.

Once the values for gain and offset are set they are memorized in the system, even when it is switched off or completely disconnected.

Deactivating "Enable Control" implicates reimplantation of the gain / offset setting of the trimmer on the camera.

The software package **SkLineScan®** contains library functions for gain and offset setting of the XSD cameras.

### Manual gain / offset adjustment:

1. Shade the line scan sensor and balance the video signal to zero voltage („00" digital) using the P1 (offset) trimmer.
2. Illuminate the sensor to a slight overexposure to identify the maximum clipping. Use the P2 (gain) trimmer to adjust the maximum output voltage.

The maximum output voltage is set to approx. 2.5 volts („FF" digital) per default.

Camera backside

To adjust the gain-setting of the pixel the camera does not need to be opened. The trimmers are accessible from the outside.

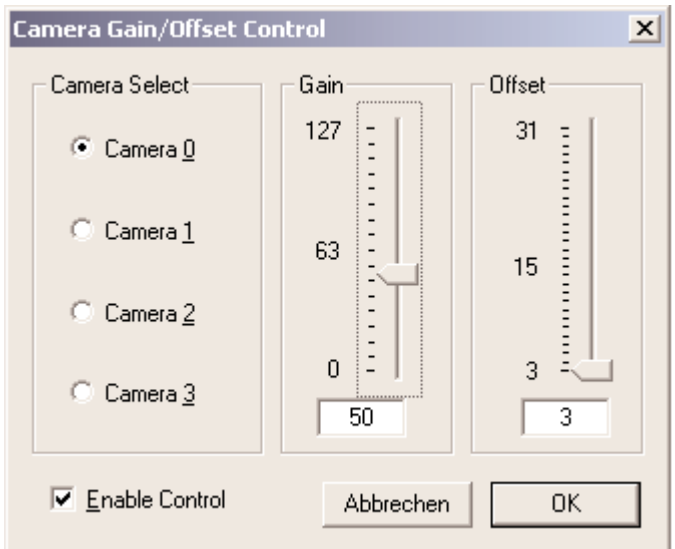
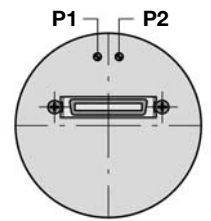

```
void SK_X_CONTROL (ccd_arg, unsigned char camera, BOOL enable)
```

```
// Enables the software control of the XSD camera or the trimmer setting of the gain / offset control.
```

```
void SK_X_SETGAIN (ccd_arg, unsigned char camera, unsigned char gain)
```

```
// Setting of the camera gain
```

```
// Camera: internal number of the XSD camera, this is set by default to one of the numbers 0...3
```

```
// Gain: setting of the gain within a range of 0...127
```

```
void SK_X_SETOFFSET (ccd_arg, unsigned char camera, unsigned char offset)
```

```
// Setting of the camera offset
```

```
// Camera: internal number of the XSD camera, this is set by default to one of the numbers 0...3
```

```
// Offset: setting of the offset within a range of 0...63
```

### Advantages of the gain / offset setting of the XSD cameras by software

- The gain / offset setting can be altered during the measurement, although the trimmer are not accessible.
- Adaption to changing illumination conditions without modifying the aperture of the lens.
- Control of the signal intensity with constant exposure time setting with the interface board.
- Matching of the signal intensities individually by operating several XSD cameras parallel with the Merger box SK9194 or SK9195

The selection of the camera is accomplished by the programmed internal number 0...3, set before delivery.

## 9. Dimension Diagrams

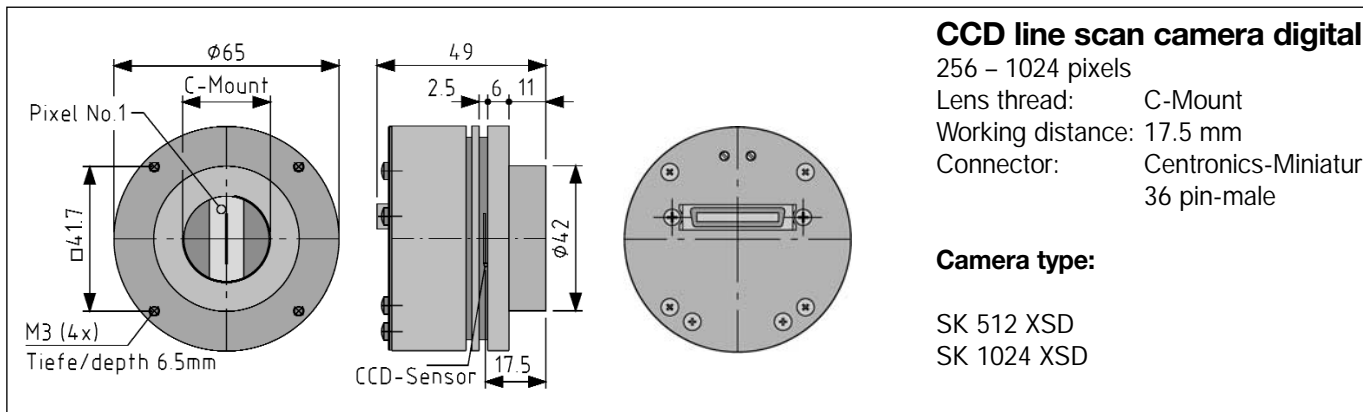

### CCD line scan camera digital

256 – 1024 pixels

Lens thread: C-Mount

Working distance: 17.5 mm

Connector: Centronics-Miniatur  
36 pin-male

### Camera type:

SK 512 XSD

SK 1024 XSD

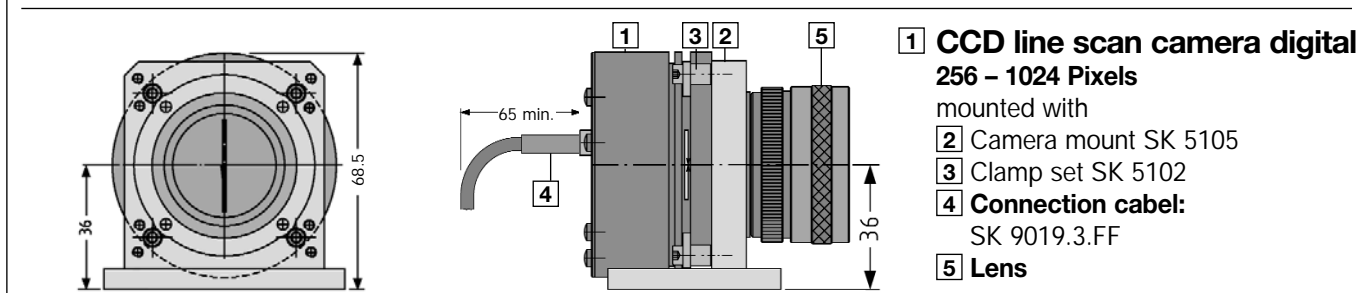

### 1 CCD line scan camera digital

256 – 1024 Pixels

mounted with

2 Camera mount SK 5105

3 Clamp set SK 5102

4 Connection cable:  
SK 9019.3.FF

5 Lens

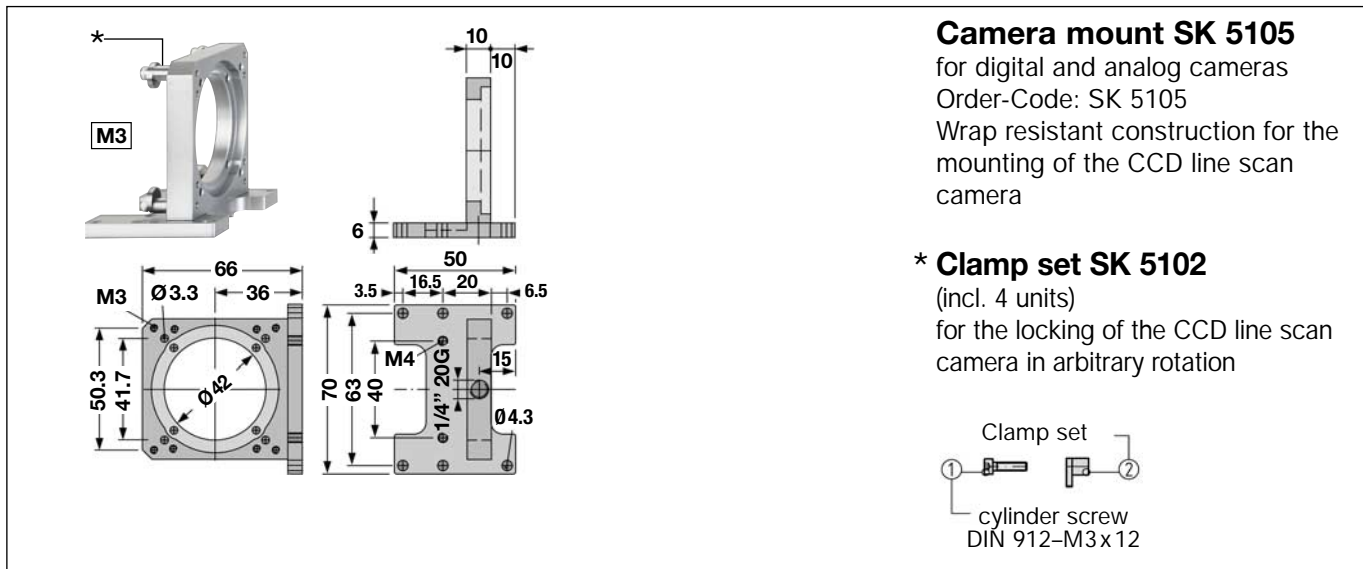

### Camera mount SK 5105

for digital and analog cameras

Order-Code: SK 5105

Wrap resistant construction for the mounting of the CCD line scan camera

### \* Clamp set SK 5102

(incl. 4 units)

for the locking of the CCD line scan camera in arbitrary rotation

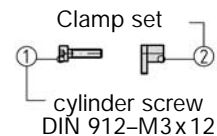

### 1 CCD line scan camera digital

256 – 1024 Pixels

mounted with

2 Camera mount SK 5105

3 Clamp set SK 5102

locking the CCD line scan camera in arbitrary rotation

### optional

4 Locking with 4 units.  
cylinder screws  
DIN 912 - M3x16

Alternative video-, enlargement and macro lenses see brochure 'CCD Line Scan Cameras' 2002 pg. K9



# 10. Sensor Data

Product by: DALSA®  
 Type: IL-P3-512, IL-P3-1024, IL-P3-2048  
 Data source: DALSA® Line Scan Sensors ,DALSA IL-P3 - Data Sheet

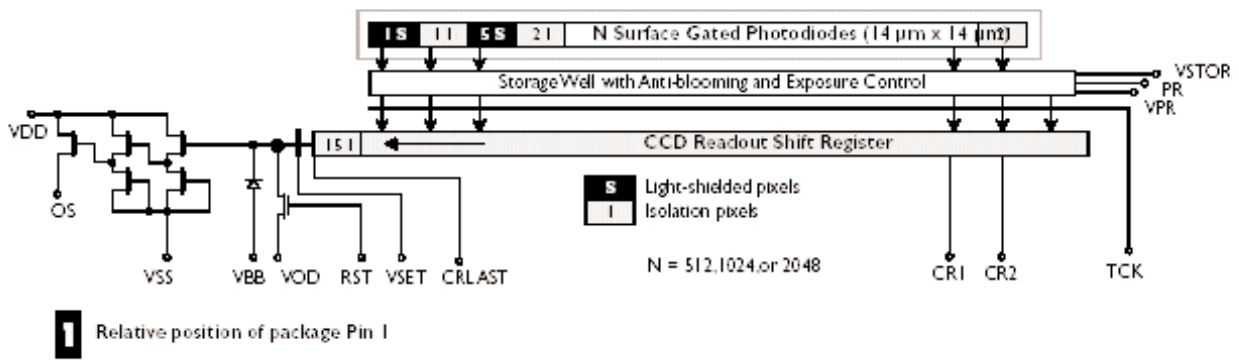

**Figure 2. Performance Measurements**

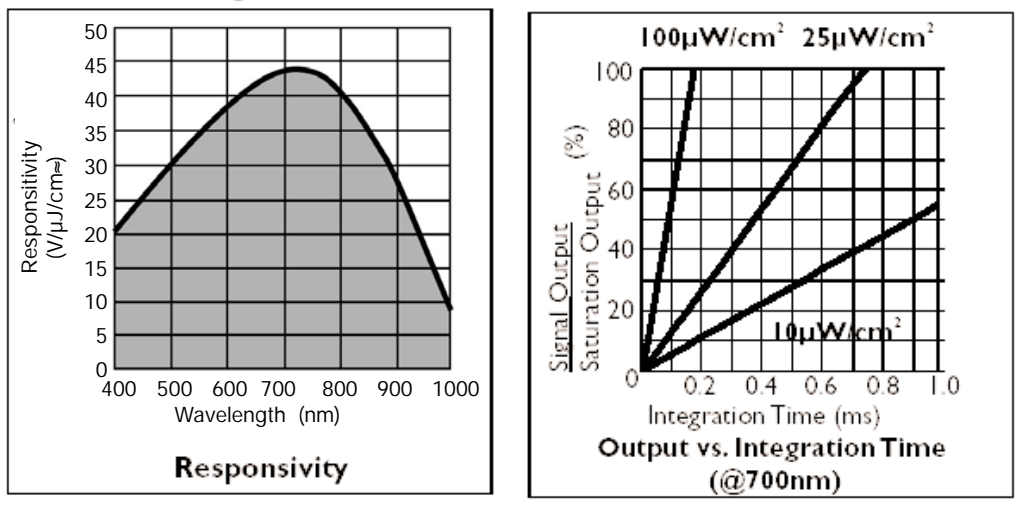

**Table 9. IL-P3 Performance Specifications**

Specification	Unit	Min.	Typ.	Max.
Saturation Output Voltage (VSAT) <sup>1</sup>	mV	680	800	930
rms Noise	mV		0.44	0.48
Wavelength of Peak Responsivity	nm		700	
Peak Responsivity	V/( $\mu\text{J}/\text{cm}^2$ )	41.3	43.7	46.5
Dynamic Range		1420:1	1820:1	2110:1
Charge Conversion Efficiency (CCE)	$\mu\text{V}/\text{e}^-$	8.8	9.3	9.9
Noise Equivalent Exposure (NEE)	$\text{pJ}/\text{cm}^2$	9	10	12
Saturation Equivalent Exposure (SEE)	$\text{nJ}/\text{cm}^2$	15	18	
Full Well Capacity <sup>1</sup>	$\text{ke}^-$	73	86	
Fixed Pattern Noise (FPN) <sup>2,3</sup>	mV		< 0.5	1.0
Photoresponse Non-Uniformity (PRNU) <sup>4</sup>	% OS			
8 pixel local neighborhood			3.0	6.5
Global			5.0	8.5
Charge Transfer Efficiency (CTE) (readout register)		0.99997	0.999999	
First Field Lag <sup>5</sup>	mV	3.1	4.3	5.4
Dark Signal, Integration time = 52 $\mu\text{s}$	mV		0.19	0.22

**Notes:**

1. VSTOR can be adjusted to increase VSAT and full well. As these quantities increase, the antiblooming capability is compromised.
2. Maximum peak-to-peak variation of all outputs.
3. Due to its general purpose design, DALSA's camera and sensor evaluation hardware provides an output that cannot be used to directly measure low FPN.
4. The peak-to-peak variation is measured at ~50% SEE.
5. Lag is measured at 500 mV. Lag is lower if signal is lower.

**Test Conditions:**

- Operating temperature = 35°C.
- $f_{RST}$  = data rate per output = 40MHz.
- $I_{LOAD}$  = 10mA.
- $C_{LOAD}$  = 10pF.
- Tungsten halogen light source, black body color temperature 3200K, filtered with 750nm IR cutoff filter.
- See Sensor Measurement Definitions (doc# 03-36-00149) for specification definitions.

**11. References and Warranty**

Although this manual has been reviewed carefully for technical accuracy, errors are possible. The reader is kindly asked to contact us, if errors are suspected.

The indicated circuits, descriptions and tables are not warranted to be free from rights of third parties.

With the statements in the technical descriptions only assembly groups are specified. Characteristics as well as the suitability for a particular purpose is not guaranteed.

The warranty period for the CCD line scan camera is 24 months. The warranty ends with inappropriate actions.

**EC-Declaration of Conformity**

	This product meets the requirement of the EC directive 89/336/E.E.G. The requirements of DIN EN 61326 are fulfilled.
---	--