

Laser type 5LT-2  
see second sheet

Allgemeintoleranz ISO 2768 - f		Maßstab: 1:1
LNC-5LT-1 + 56CM		
Bearb.	25.07.2023	Name Trapp
Gepr.		
Norm		
Schäfter&Kirchhoff OPTO-SENSORIK UND MESSTECHNIK <small>OPTIK-ENTWICKLUNG/ELEKTRONIK/SENSORTECHNIK/MESSTECHNIK</small>		Blatt A3
9304-1200-0141		Blatt: 1
Zust.	Änderungen	Datum
Datei: 930412000141.idw		Model: 930412000141.iam

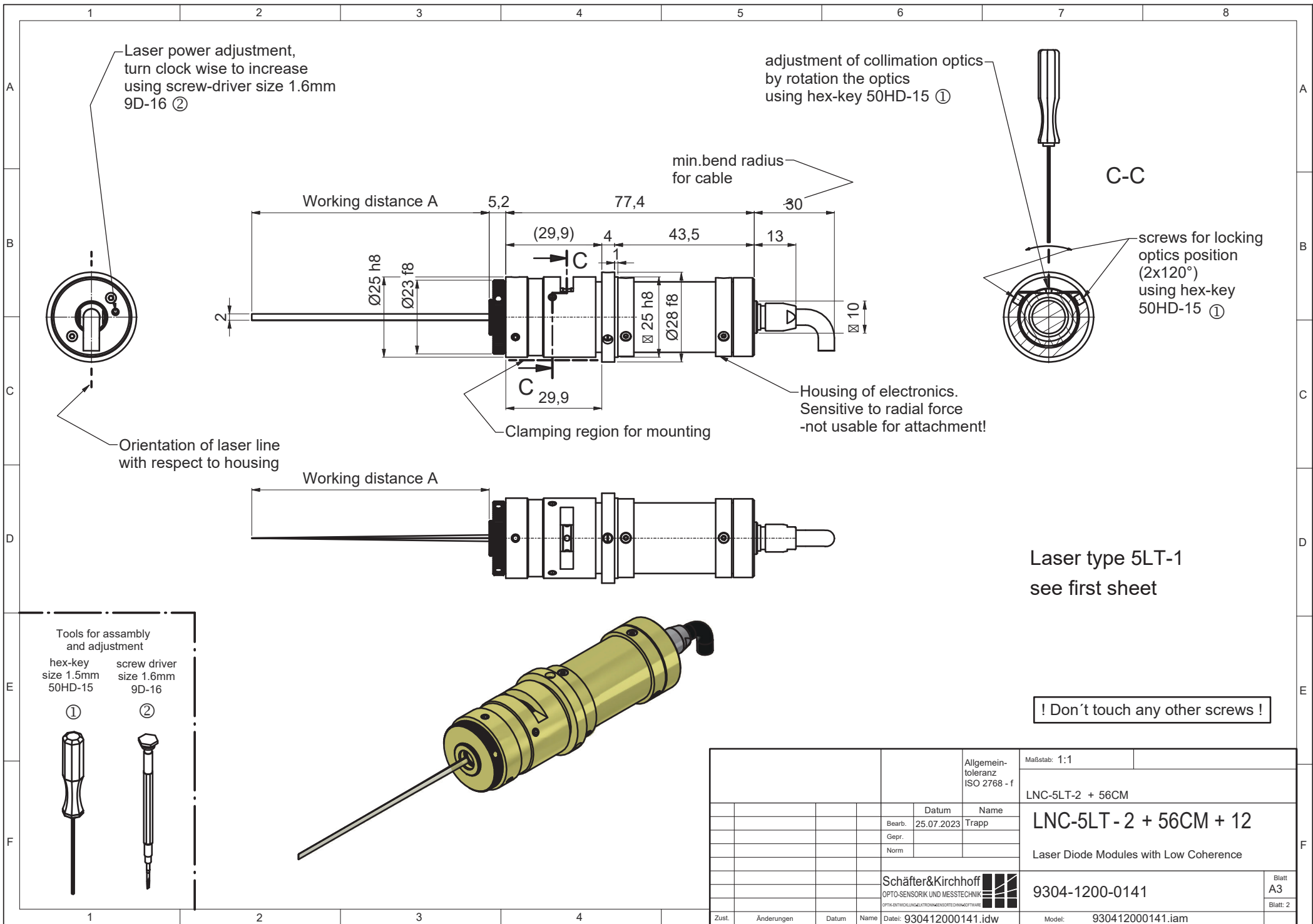

Laser type 5LT-1  
see first sheet

! Don't touch any other screws !

**Tools for assembly and adjustment**

hex-key size 1.5mm 50HD-15	screw driver size 1.6mm 9D-16
①	②

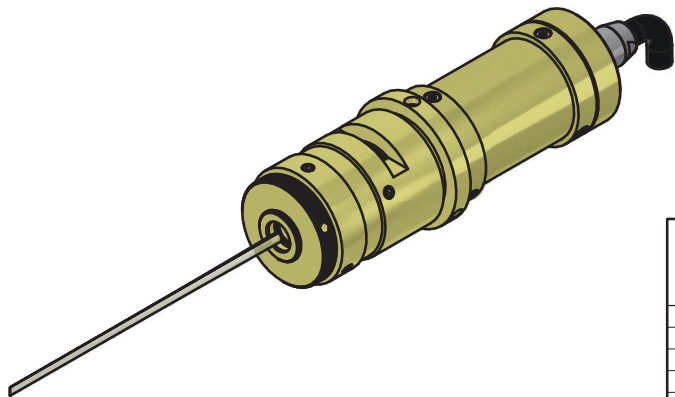

Allgemeintoleranz ISO 2768 - f		Maßstab: 1:1
LNC-5LT-2 + 56CM		
Bearb.	25.07.2023	Name Trapp
Gepr.		
Norm		
Schäfter&Kirchhoff OPTO-SENSORIK UND MESSTECHNIK <small>OPTIK-ENTWICKLUNG/ELEKTRONIK/SENSORTECHNIK/MESSTECHNIK</small>		Blatt A3
9304-1200-0141		Blatt: 2
Zust.	Änderungen	Datum
Datei: 930412000141.idw		Model: 930412000141.iam