

! Don't touch any other screws !

For information only
Not for manufacturing purposes

Dimensions DIN EN ISO 14405			Scale: 2:1
		5LTM-11+25CM-66	
		Date	Name
		editor	23.02.2021 A.Trapp
		exam.	
		free	
		Customer Drawing	
		Schäfer+Kirchhoff OPTICS, METROLOGY, AND PHOTONICS	9211-2000-0636
		File: 921120000636.idw	Model: 921120000636.iam
		Size: A2	Page: 1

A

B

C

D

E

F

A

B

C

D

E

F

Laser power adjustment,
turn clock wise to increase
using screw-driver size 1.6mm
9D-16 ③

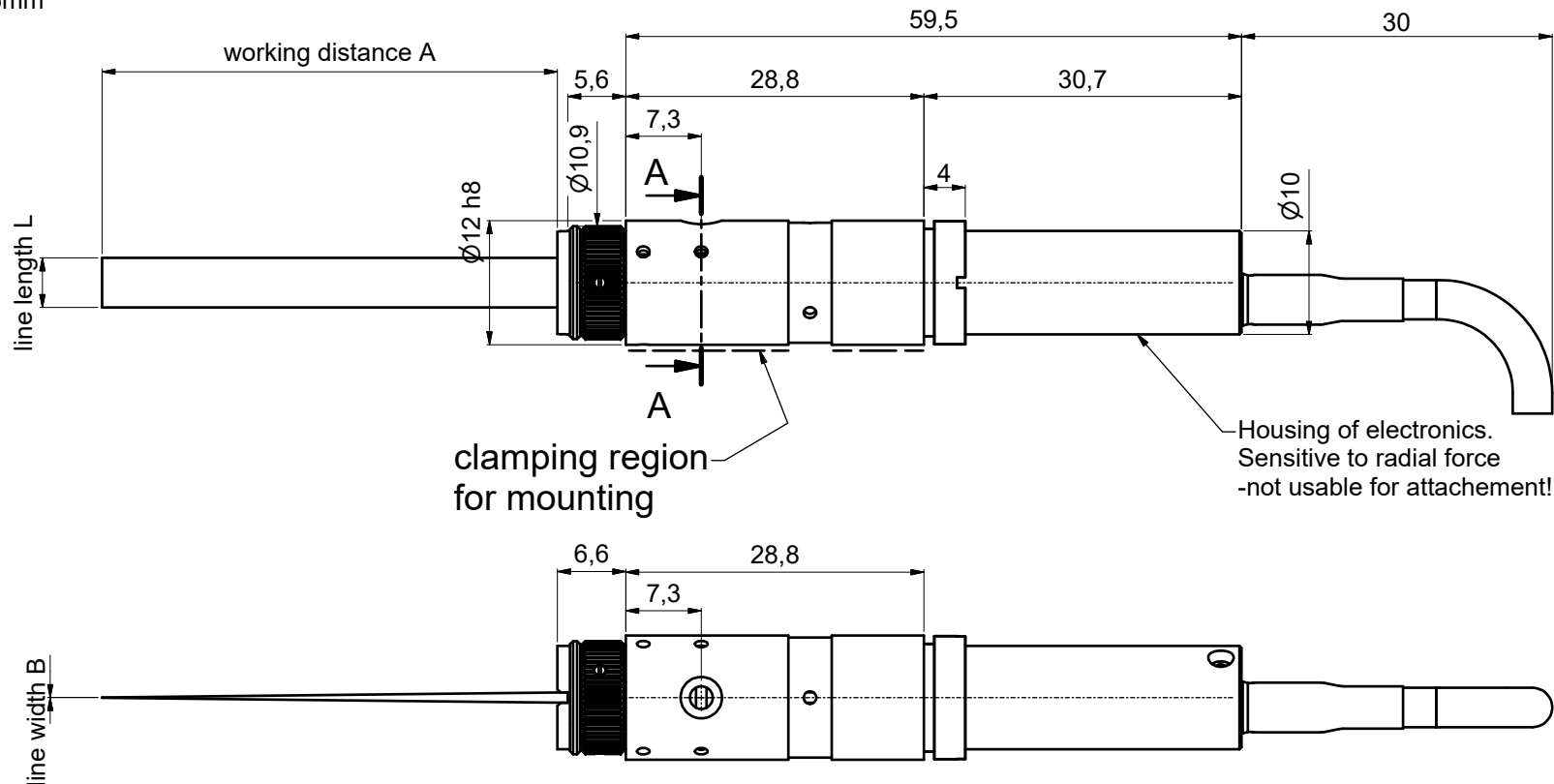
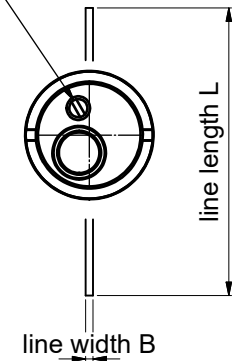

A-A adjustment of focus setting
using eccentric-key 60EX-4 ②

clamp screws
for locking optics position (2x120°)
using screw-driver size 1.2mm
9D-12 ①

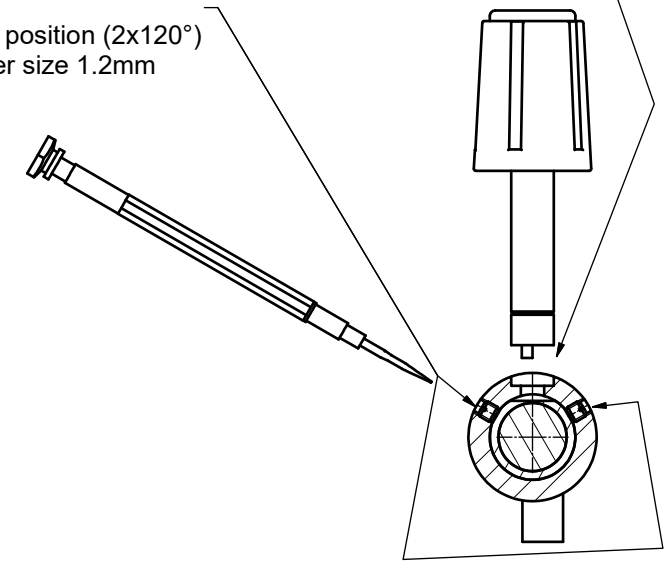

Tools for assembly and adjustment

screw driver size 1.2mm 9D-12 eccentric-key 60EX-4 screw driver size 1.6mm 9D-16

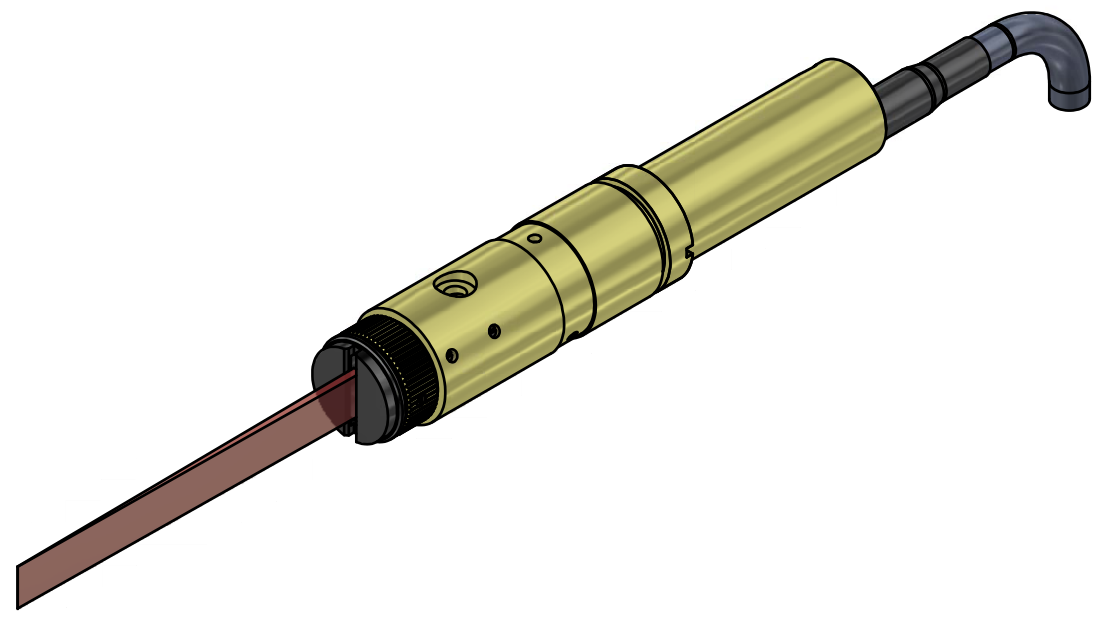
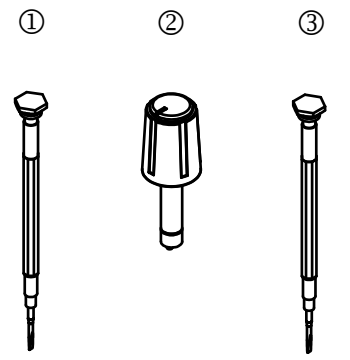

! Don't touch any other screws !

For information only
Not for manufacturing purposes

Dimensions DIN EN ISO 14405			Scale: 2:1
		5LTM-22+25CM-66	
		Date	Name
		editor	23.02.2021 A.Trapp
		exam.	
		free	
		Customer Drawing	
		Schäfter+Kirchhoff OPTICS, METROLOGY, AND PHOTONICS	
		9211-2000-0637	
		File: 921120000637.idw	Model: 921120000637.iam
		Size: A2	Page: 1