

Laser power adjustment, clockwise twist to increase

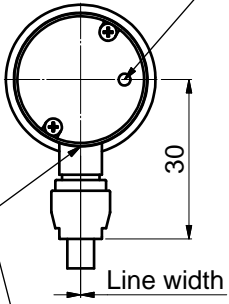

Orientation of laser line with respect to housing

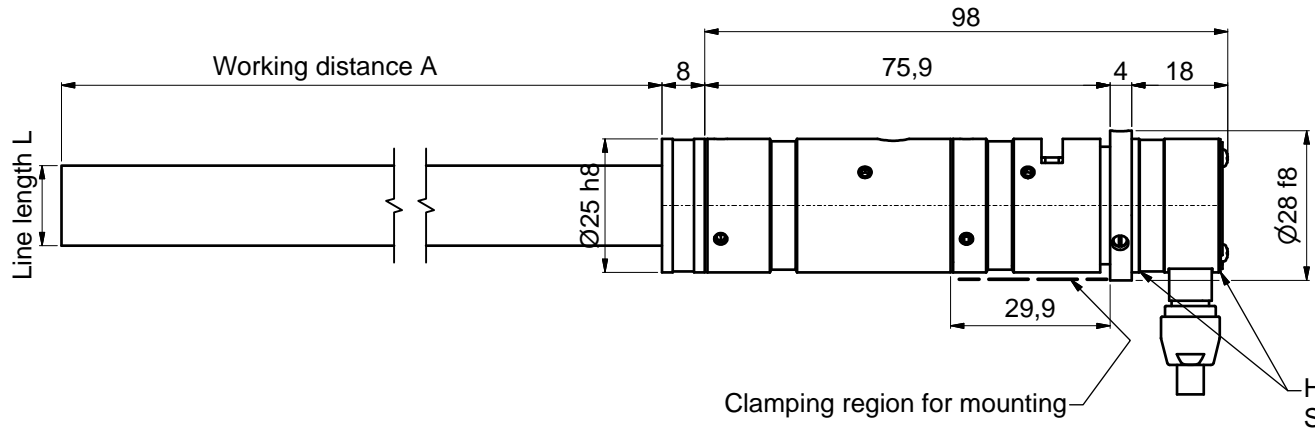

Clamping region for mounting

Housing of electronics. Sensitive to radial force -not usable for attachment!

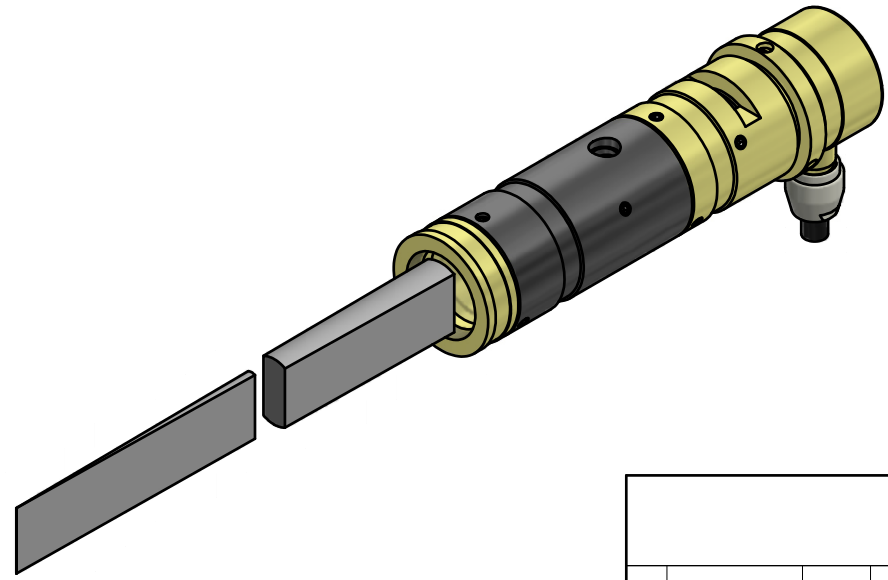

! Don't touch any other screws !

		Allgemeintoleranz ISO 2768 - f		Maßstab: 1:1	
		13LT-xxx + 90CR		13LT-xxx + 90CR X=8	
		Datum	Name		
		Bearb. 27.11.2013	Trapp		
		Gepr.			
		Norm		13LT-xxx + 90CR	
			Schäfter&Kirchhoff		Blatt A3
			OPTO-SENSORIK UND MESSTECHNIK		9304-1200-0127
			OPTIK-ENTWICKLUNG/ELEKTRONIK/SORTIMENT/SOFTWARE		Blatt 1
Zust.	Änderungen	Datum	Name	Datei: 930412000127.idw	Modell: 930412000127.iam