

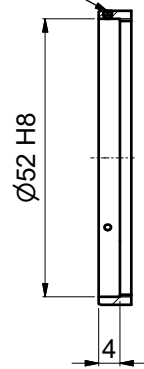

Clamping screw for locking of lens attachments (3x120°)

A-A



Thrust and tension screw (3x120°) for tilt adjustment with hex key wrench size 1.5mm 50HD-15 ①

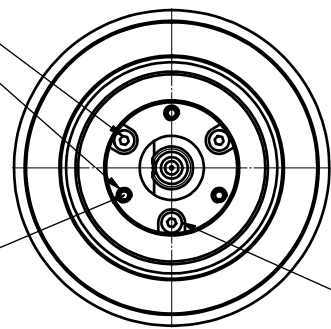

Thrust screw M3 max.torque 50Ncm

Tension screw M2 max.torque 40Ncm

! Pin screw for additional locking of the fiber ferrule:
 - before pulling the FC-connector:
 unlock the pin screw.
 - before inserting the FC-connector:
 make sure the ferrule receptacle is not blocked by the pin screw !

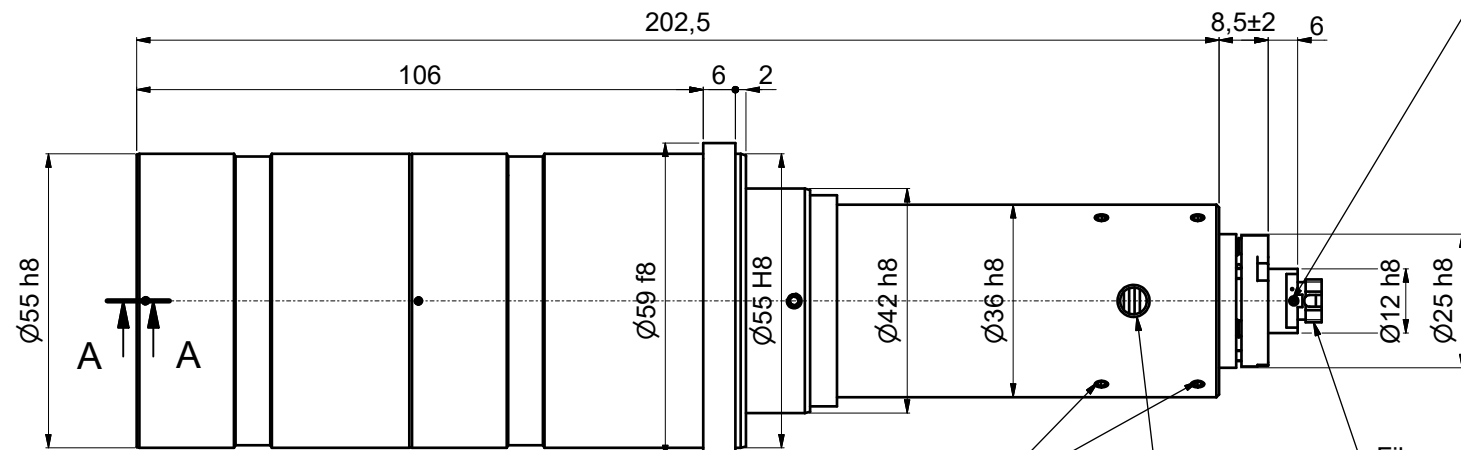

Fiber receptacle type FC-PC (wide key)

adjustment of focus setting using eccentric-key 55EX-5 ③

Stop screw (2x/3x120°) for locking optics position using hex key 1.5mm 50HD-15 ①

! Don't touch any other screws !

Tools for assembly and adjustment

hex-key size 1.5mm 50HD-15 screw driver size 1.2mm 9D-12 eccentric-key 55EX-5

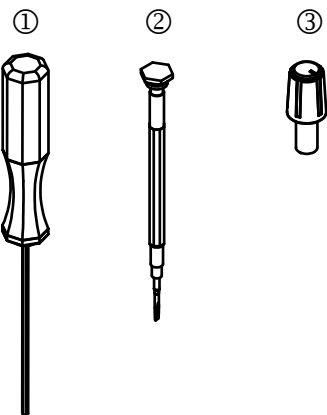

Allgemeintoleranz ISO 2768 - f		Maßstab: 2:1	
Datum		Name	
Bearb.	08.09.2016	Gepr.	60FC-T-0-M200-xx
Norm		Fiber receptacle type FC-PC	
Schäfter&Kirchhoff OPTO-SENSORIK UND MESSTECHNIK		9802-4150-0027	
Date: 980241500027.idw		Model: 980241500027.iam	
Zust.	Änderungen	Datum	Name