

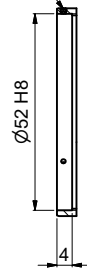

Clamping screw for locking of lens attachments (3x120°) screws not included

A-A



! Pin screw for additional locking of the fiber ferrule:  
 - before pulling the FC-connector: unlock the pin screw.  
 - before inserting the FC-connector: make sure the ferrule receptacle is not blocked by the pin screw !

Thrust and tension screw (3x120°) for tilt adjustment with hex key wrench size 1.5mm 50HD-15 ①

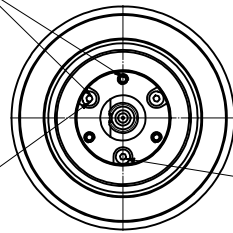

Thrust screw M3 max.torque 50Ncm

Tension screw M2 max.torque 40Ncm

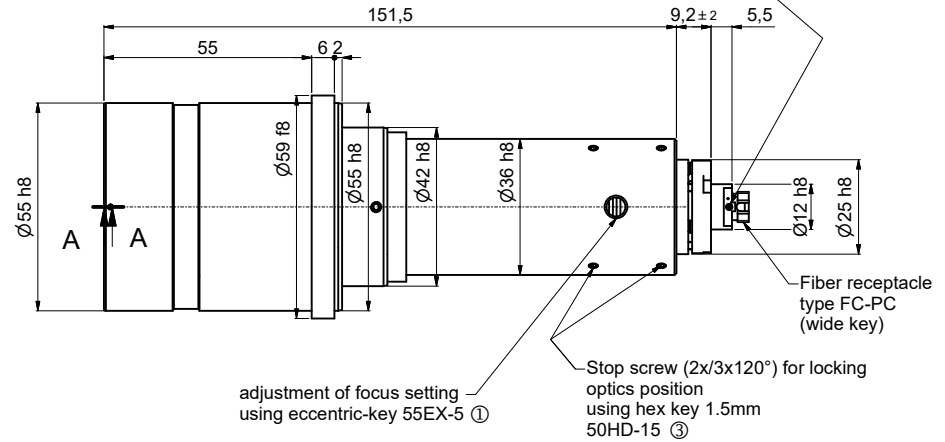

Tools for assembly and adjustment

- hex-key size 1.5mm 50HD-15
- screw driver size 1.2mm 9D-12
- eccentric-key 55EX-5

①



②

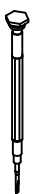

③



For information only  
 Not for manufacturing purposes

! Don't touch any other screws !

		Allgemeintoleranz ISO 2768 - f		Maßstab: 2:1	
		Datum Name		60FC-T-0-M150-xx	
		Bereb. 18.05.2016 A.Trapp		60FC-T-0-M150-xx	
		Gepr.		Fiber receptacle type FC-PC	
		Norm		8402-4150-0031	
		Schäfer&Kirchhoff OPTO-SENSORIK UND MESSTECHNIK		Blatt A2	
		9802-4150-0031		Blatt: 1	
Zust.	Änderungen	Datum	Name	Datei: 980241500031.idw	Model: 980241500031.iam