

Thrust and tension screw (3x120°)
for tilt adjustment
with hex key wrench size 1.5mm
50HD-15 ①

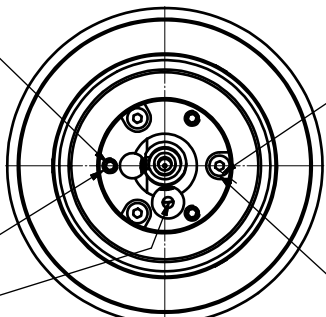

Rotation of the quarter wave plate
with adjustment key ④

Thrust screw M3 max.torque 50Ncm

Tension screw M2 max.torque 40Ncm

Tools for assembly and adjustment

hex-key size 1.5mm 50HD-15	screw driver size 1.2mm 9D-12	eccentric-key 55EX-5	Adjustment key 60Z-2303
----------------------------------	-------------------------------------	-------------------------	----------------------------

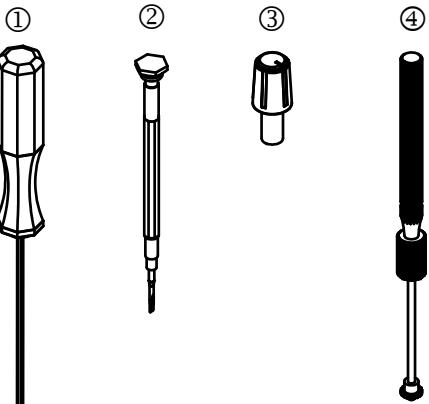

A-A



Clamping screw for locking of
lens attachments (3x120°)

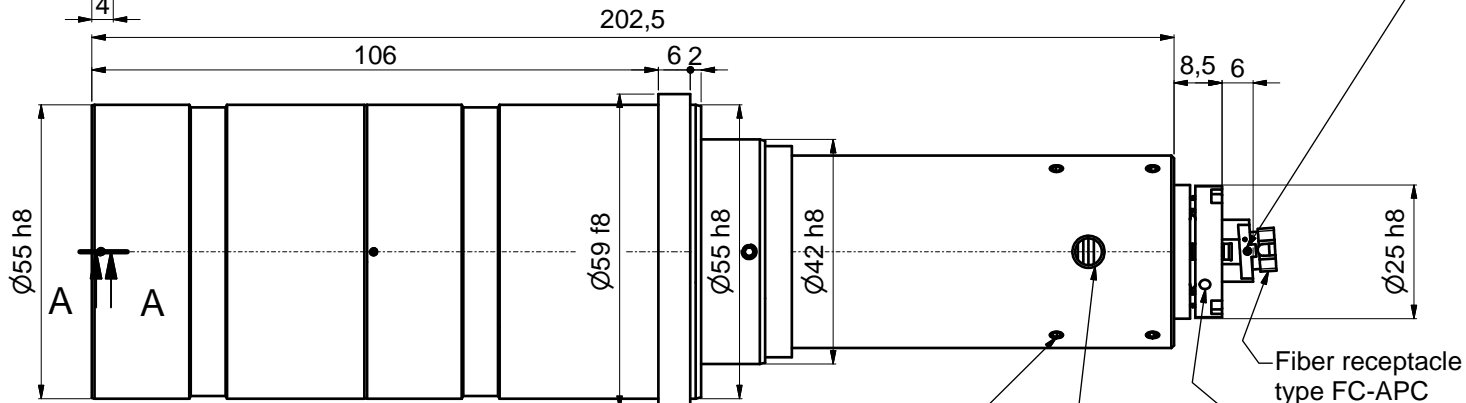

! Pin screw for additional locking of the fiber ferrule:
- before pulling the FC-connector:
unlock the pin screw.
- before inserting the FC-connector:
make sure the ferrule receptacle is not blocked
by the pin screw !

Stop screw (2x120°) for lock/unlock
of the rotation of the
quarter wave plate
with hex-key 1.5mm 50HD-15 ①

adjustment of focus setting
using eccentric-key 55EX-5 ③

Stop screw (2x120°) for lock/unlock
of the rotation of the
quarter wave plate
with screw driver 1.2mm 9D-12 ②

Fiber receptacle
type FC-APC
(wide key)

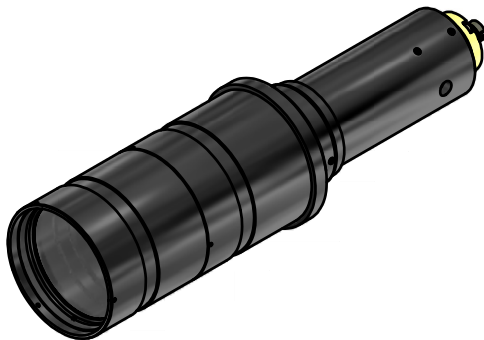

! Don't touch any other screws !

Allgemein- toleranz ISO 2768 - f		Maßstab: 2:1	
60FC-Q-4-M200-xx		60FC-Q-4-M200-xx	
Bearb.	Datum	Name	60FC-Q-4-M200-xx
18.05.2016		A.Trapp	
Gepr.			
Norm			Fiber receptacle type FC-APC
Schäfter&Kirchhoff OPTO-SENSORIK UND MESSTECHNIK OPTIK-ENTWICKLUNG/ELEKTRONIK/SERVENTECHNIK/SOFTWARE			Blatt A3
9802-4150-0025			Blatt: 1
Zust.	Änderungen	Datum	Name
			Datei: 980241500025.idw
Modell: 980241500025.iam			