

! Pin screw for additional locking of the fiber ferrule:
 - before pulling the FC-connector:
 unlock the pin screw.
 - before inserting the FC-connector:
 make sure the ferrule receptacle is not blocked
 by the pin screw !

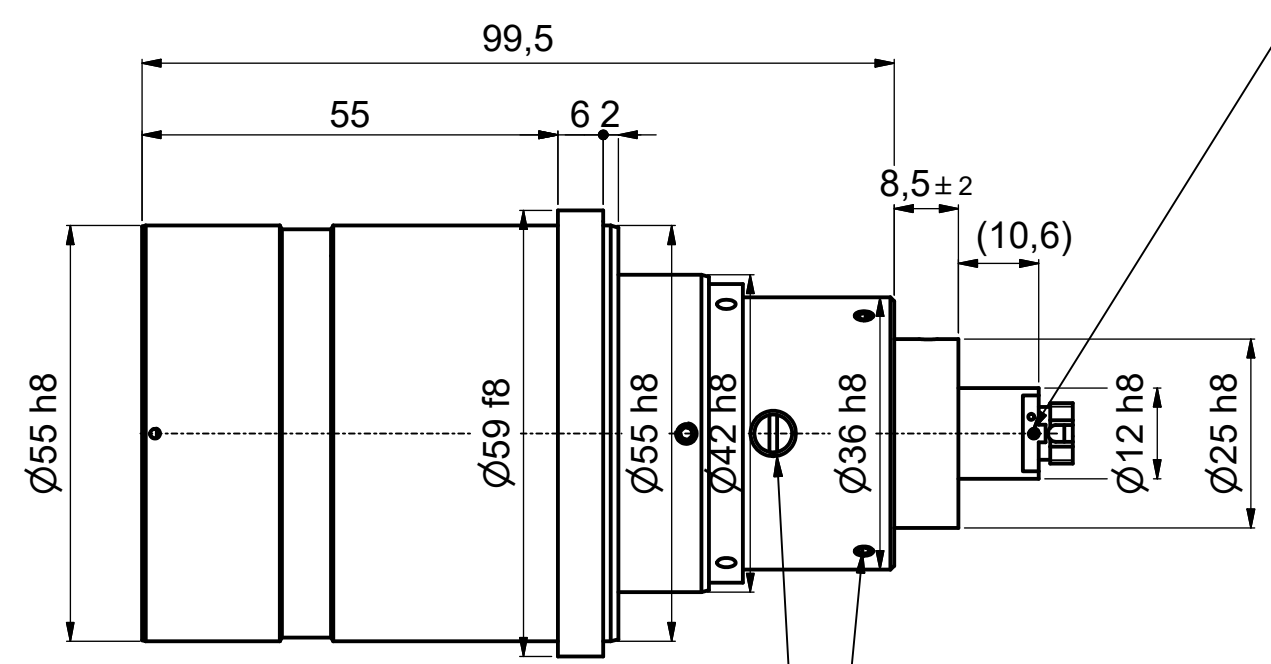

adjustment of focus setting
 using eccentric-key 55EX-5 ③

Stop screw (3x120°) for locking
 optics position
 using hex key 1.5mm
 50HD-15 ①

! Don't touch any other screws !



Tools for assembly and adjustment

- hex-key size 1.5mm 50HD-15
- screw driver size 1.2mm 9D-12
- eccentric-key 55EX-5

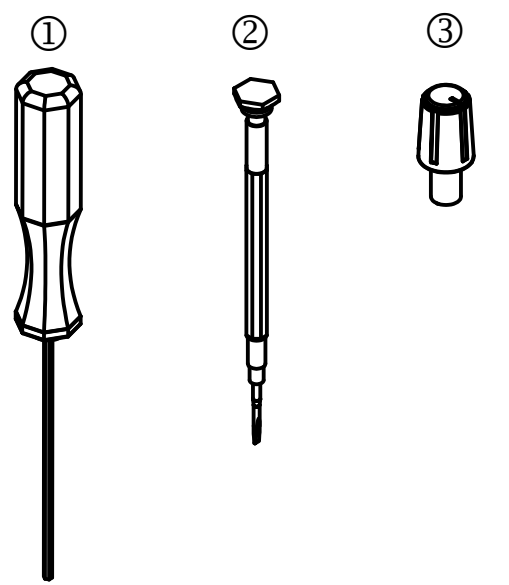

Maße DIN EN ISO 14405		Maßstab: 1:1		60FC-L-0-M100-xx		Rohteil:	
		Datum		Name		Faserkollimator	
		Bearb. 02.05.2023		Tp		60FC-L-0-M100-xx	
		Gepr.				Zusammenbauzeichnung	
		Freigegeben				9802-4180-1400	
				Schäfter+Kirchhoff OPTICS, METROLOGY, AND PHOTONICS GmbH		Blatt A3	
Zust.		Änderungen		Datum		Name	
				Datei: 980241801400.idw		Blatt: 2	
				Datei: 980241801400.idw		Modell: 980241801400.iam	