

Fiber Port Clusters for Magneto-Optical Traps

Fiber-coupled beam delivery systems. Postcard size replaces 1 m² breadboard constructions. Assembled with fiber optic components from Schäfter+Kirchhoff.

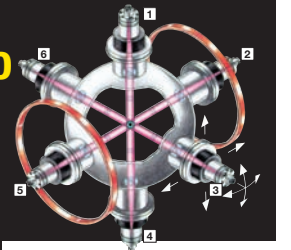
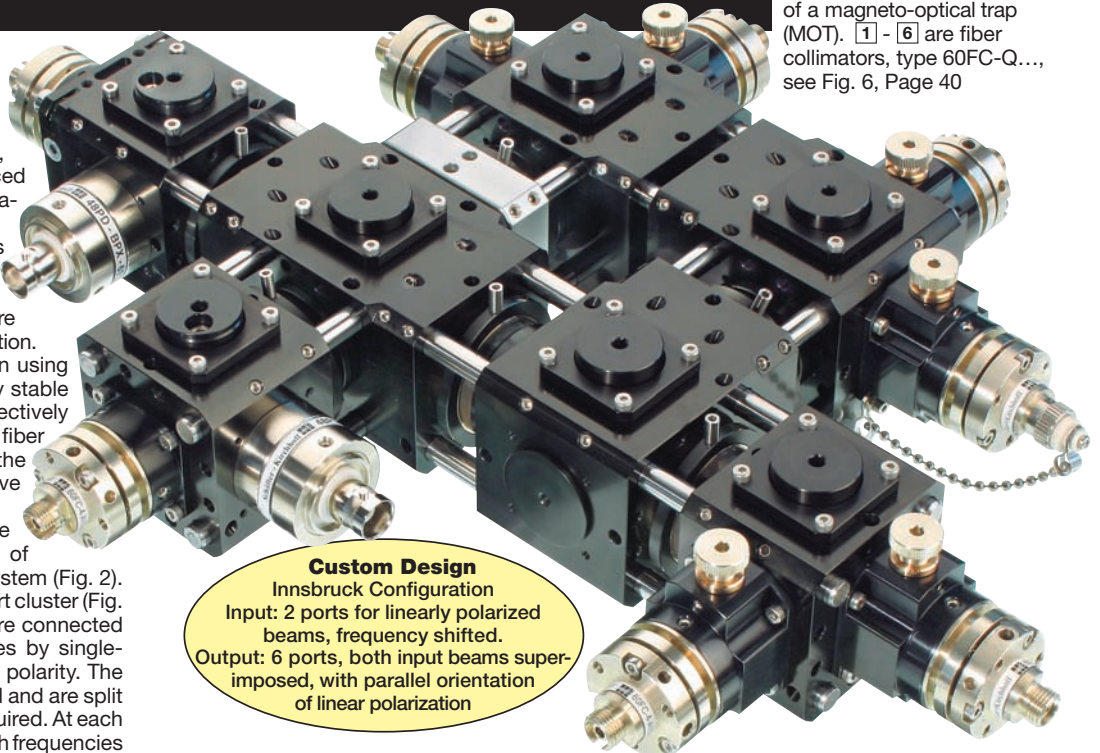

Figure 1: Schematic layout of a magneto-optical trap (MOT). 1 - 6 are fiber collimators, type 60FC-Q..., see Fig. 6, Page 40

The cooling of an atomic cloud down to a very few micro-Kelvin in an atomic trap brings thermal motion to a virtual standstill. To reach micro-Kelvin temperatures, a magneto-optical trap produced from magnetic fields and laser radiation is used (Fig. 1). A magneto-optical trap (MOT) is often used for the initial cooling phase before other super-cooling mechanisms bring the temperature down for Bose-Einstein condensation. Experimental reproducibility when using cold atoms requires an extremely stable setup. This is achieved most effectively by using polarization-maintaining fiber optics to mechanically decouple the vibration and temperature sensitive optics from the trap. Efficiency and reproducibility are the fundamental characteristics of our multimodular fiber delivery system (Fig. 2). The optical scheme of the fiber port cluster (Fig. 3) shows that the 2 input ports are connected to their frequency-shifted sources by single-mode fibers which maintain laser polarity. The 2 light sources are then combined and are split between the 6 output ports as required. At each output port, the polarization of both frequencies is orientated in parallel and coupled into a polarization-maintaining singlemode fiber. The six output fibers and their fiber collimators, optionally fitted with integrated quarter-wave retarders, are attached to the MOT (Fig. 1). The delivered fiber port cluster is assembled and pre-aligned, together with highly detailed manuals if further adjustment is desired. The coupling of laser radiation into singlemode fibers and their correct orientation with the axes of polarization are performed using computer-assisted beam and polarization analysis. This automation substantially reduces the alignment effort, especially in comparison with a more conventional breadboard configuration. Laser beam couplers, splitters and combiners, polarizers and retardation optics can be mixed together using "multicubes" to produce almost any desired system in a postcard size (Fig. 5). The 1 m² and bigger breadboard arrangements are totally superseded by this fully integrated, ultra-compact, transportable sealed system.



Custom Design
Innsbruck Configuration
Input: 2 ports for linearly polarized beams, frequency shifted.
Output: 6 ports, both input beams superimposed, with parallel orientation of linear polarization

Figure 2: Fiber port cluster 2 → 6. Manufactured for IQOQI, Austrian Academy of Sciences

Figure 3: Optical scheme of configuration in Figure 2

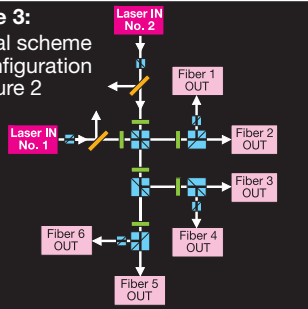

Designed for Isotope	Wavelength
Sr	461
Yb	556
Na	589
Li	671
Sr	689
Na	760
K	767
Rb	780
Kr	811
Cs	852
He	1083

In global use:	
	Austria
	France
	Germany
	Italy
	U.K.
	USA
	VR China
	India

Figure 4: Example Application

Fiber Port Clusters in Micro-Gravity Experiments



The compactness and ruggedness of the fiber port clusters from Schäfter+Kirchhoff have been rigorously demonstrated in the demanding micro-gravity environment of parabolic flights. The atom-optics rack of the atom interferometer was designed by the French Institut d'Optique in Palaiseau and collaborators (arXiv:0705.2922v2 [physics.atom-ph]).



The fiber port cluster has fully proven its robustness against the extremes of vibration, pressure and temperature in these parabolic flights

- 1 vacuum chamber
- 2 fiber collimator
- 3 fiber port cluster

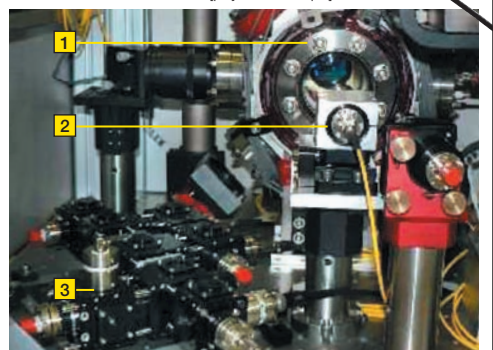
Figure taken from arXiv:0705.2922v2 [physics.atom-ph]

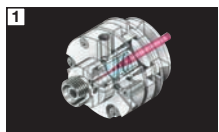

Modular components from Schäfter+Kirchhoff

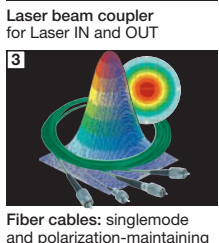
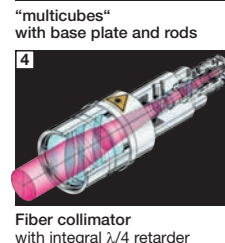
 <p>1 Laser beam coupler for Laser IN and OUT</p>	 <p>2 "multicubes" with base plate and rods</p>
 <p>3 Fiber cables: singlemode and polarization-maintaining</p>	 <p>4 Fiber collimator with integral λ/4 retarder</p>

Atomtrap_Act_FiberOptics_09_E.indd • Page 40

Fiber Port Cluster 1→4

Fiber port clusters made by Schäfter+Kirchhoff take the optical power carried by a polarization-maintaining singlemode fiber and split it into multiple polarization-maintaining singlemode fibers with high efficiency. Additionally, numerous bulk-optical components can be integrated and, by use of actuating elements, the splitting ratio of the resultant beams can be adjusted arbitrarily and reproducibly. In principle, the cluster can be cascaded endlessly in order to generate any desirable number of outgoing ports. (for a fiber port cluster 2→6, see page 40).

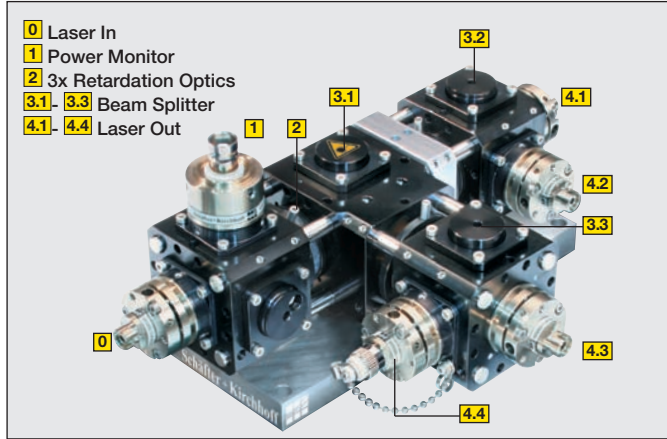

Figure 5: Fiber port cluster 1→4 with integrated power monitor, retardation optics, beam splitter and laser beam couplers for singlemode fibers.

Figure 5 depicts a 1→4 cluster with the incoming port 0 connected via a laser beam coupler to a polarizer. The polarizer defines the incoming polarization state even in the case of a source with weak polarization stability. A 98/1 beam splitter combined with a photo-detector acts as a power monitor 1. The majority of the radiation passes the first half-wave retardation plate 2 that is mounted in a self-locking bearing free from backlash. The half-wave retarder rotates the axis of the incoming polarization in the freely adjustable range from 0:100 to 100:0 and so defines the splitting ratio reaching the polarization beam splitter 3.1. Rotatable half-wave retarders and a further set of polarization beam splitters 3.2 and 3.3 are placed at each outgoing port to divide the beams yet again. There are now a total of four beams passing through the laser beam couplers 4.1 - 4.4 which act as the outgoing ports. Polarizing beam splitters produce a high degree of polarization in the non-deflected beam (typically 1:10,000). Conversely, the low degree of polarization in the deflected beam (typically 1:20) necessitates the use of small additional polarizers to increase the degree of polarization of these deflected beams. Polarization-maintaining singlemode fibers are connected to the outgoing ports.

Figure 6 depicts the system components and the optical path arrangement schematically.

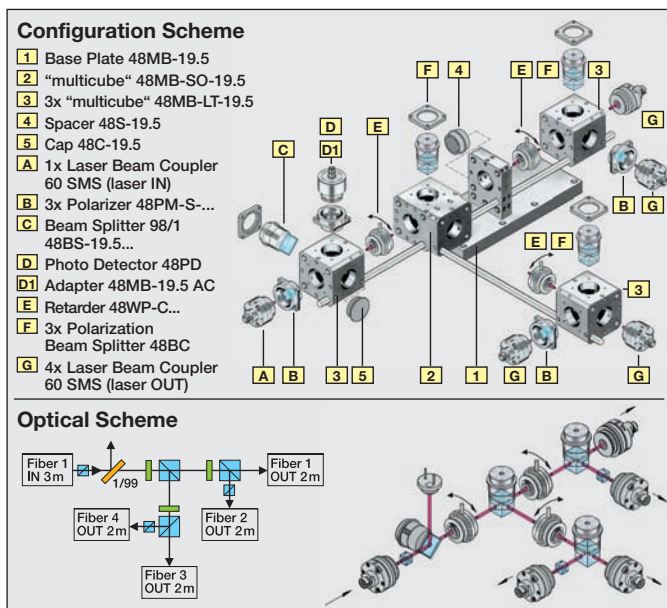

Figure 6: System components for the fiber port cluster shown in Figure 5.

Alignment and Beam Analysis using CCD cameras

The quality of a fiber port cluster is determined by its polarization maintenance ability and the power efficiency of the coupled laser radiation. The plano-optics, beam splitters and combiners need a highly precise alignment. Even the smallest deviations of the beam from the optical axis can lead to obstruction, diffraction or aberration and, thus, to reduced coupling efficiency at the outgoing ports. The quality and precision of the connection between a laser beam coupler and its polarization-maintaining singlemode fiber cable is absolutely critical for the functionality of a fiber port cluster.

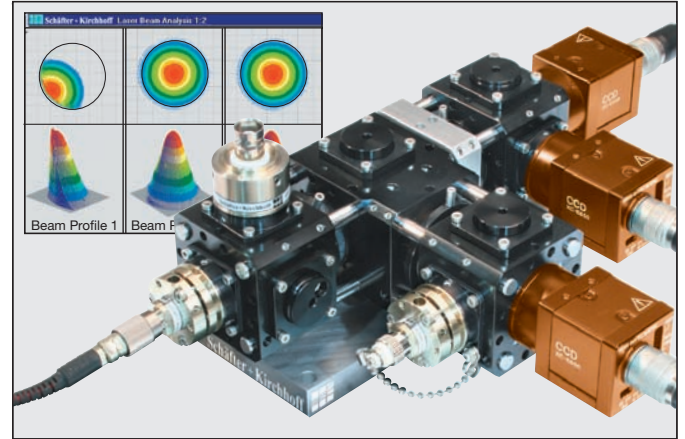

Figure 7: Fiber port cluster 1→4 with cameras attached to ports 4.1 to 4.3 for the monitoring of the alignment process.

Fig. 10B) are provided for a large variety of wavelengths and beam diameters. The tilt adjustment and inner focussing mechanism provide all of the degrees of freedom needed for alignment, while being compact and insensitive to unintentional displacement. The inclined coupling axis, provided by the fiber connectors of the FC-APC type, ensures that back-reflections into the optical path and laser source are avoided.

The laser beam couplers have two different tasks in a fiber port cluster. One is to collimate the radiation that is emitted from the singlemode fiber at the incoming port. The other is to couple the split radiation into the singlemode fibers at the outgoing ports.

The "multicube" system from Schäfter+Kirchhoff is the integrating element for the fiber port cluster (Fig. 6) and provides a warp-resistant assembly of laser beam couplers.

To maintain optimal polarization and beam profile characteristics, an expert and careful selection of the materials is required. Additionally, we take the utmost care to obviate mechanical stress during fiber termination in the coupler. Polarization-maintaining singlemode fiber cables are provided by Schäfter+Kirchhoff in a variety of wavelengths.

Figure 7 shows the fiber port cluster depicted in Figure 5 during alignment adjustment. All beam splitters and half-wave retarders are already mounted and, instead of laser beam couplers, CCD cameras have been attached to the outgoing ports 4.1 to 4.3.

The laser power incident on the sensitive cameras has to be reduced during the adjustment process. A vignetting aperture is produced by rotating the half-wave retardation plates, restricting the collimated laser beam to 5% of its full strength. The computer-assisted image analyzer determines the quality of the laser beam being coupled and uses a two-dimensional Gaussian to center the beam.

The screenshot (inset, Fig. 7) reveals the position of the collimated beam at the sensor of port 4.1 that originates from the input port 0. The left-hand beam profile shows that the beam is asymmetrically obstructed and, so, the laser beam coupler at port 0, employed as collimator, has to be realigned using its tilt adjustor. The middle and right-hand beam profiles show the beam aligned correctly.

The beam positions at the outgoing ports 4.2 and 4.3 are now aligned by tilting their respective beam splitters 3.1 and 3.2. Finally, the beam position at port 4.4 is aligned by tilting its beam splitter 3.3.

After all adjustments have been completed, the cameras are replaced by laser beam couplers. The alignment of the fiber cable at the outgoing ports is performed using the tilt adjustment and, when needed, by fine-adjustment of the focus for each of the four couplers.

The fully aligned fiber port cluster is now stable for transport and can be utilized without any requirement for a space-consuming optical breadboard.

Polarization Maintainance and Analysis

Laser beam propagation in polarization-maintaining singlemode fibers enables countless modular and compact systems to be devised for scientific experimentation and measurements. The advantages of the substantial flexibility in spatial arrangements are complemented by the high intensity and Gaussian distribution of the beam emanating from our singlemode fibers. The potential problem of polarization fluctuations are totally obviated using modular fiber-optic system components with specially designed and precise adjustment mechanisms.

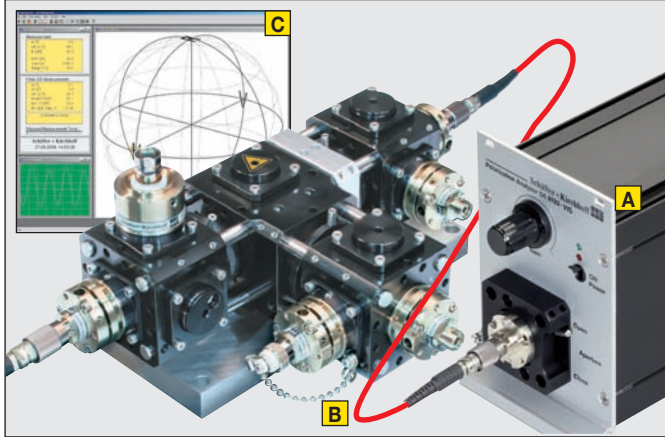

Figure 8: Polarization measurement. **A** SK9782 VIS/NIR Analyzer, **B** polarization-maintaining singlemode fiber, **C** display screenshot

Polarization fluctuations in the fiber output is considered to hinder the effective replacement of a bulk-optical breadboard by a modern fiber-optical system. While the use of inappropriate polarization-maintaining singlemode fibers can cause polarization fluctuations, it is usually the inadequate and suboptimal alignment of the polarization axis with the axes of the polarization-maintaining fibers that causes these problems. Modular fiber-optical systems also eliminate the need for elaborate opto-mechanical spatial filtering, with its resultant beam intensity loss. Polarization-maintaining singlemode fibers maintain the oscillation of the electromagnetic field in two orthogonal axes: one with fast and the other with slower light-propagating properties. When linearly polarized radiation is not coupled exactly with one of these axes, the beam is transformed into an elliptical polarization state because of the different light propagation speeds in the two axes. Temperature changes, fiber bending and even vibration can affect the polarization state obtained at the end of the fiber.

The SK9782-VIS/NIR polarization analyzer (Fig. 8) is a plug&play USB device developed for ease of use by practitioners in the field. Alignment measurements and verification are achieved more rapidly than with the more time-consuming conventional methods.

The state of polarization (SOP) is displayed in real-time as the Stokes parameter or as a point on a Poincaré sphere with azimuth and inclination angle. By maximising a bar display of the extinction ratio, the axial alignment of a polarization-maintaining fiber can be achieved.

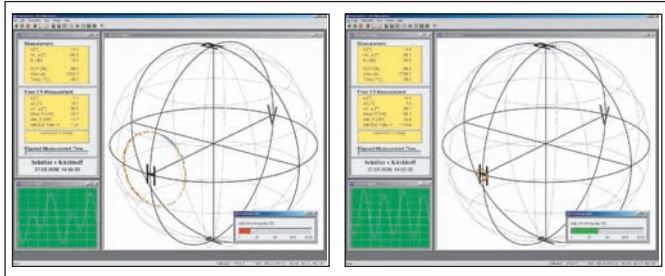

Figure 9: Polarization analyzer software: measuring of extinction ratios

Left When linearly polarized radiation is not coupled exactly to one of the fiber polarization axes then the state of polarization can fluctuate with temperature or fiber position. The misaligned polarization axis, indicated by a ring around H, is realigned by maximizing the extinction ratio using a continuously updated red-green bar display (inset).

Right A second measurement of the extinction ratio indicates that the polarization state fluctuation is reduced, the ring is reduced to a small spot at H on the equator, denoting a stable linear state of polarization.

The final extinction ratio is displayed on a linear and a logarithmic scale.

Figure 10: System Components
Optical system building blocks for self-assembly and alignment

For examples and applications, see Figures 4 and 5

A "multicubes" 48MC-...
The "multicubes" **1** and **2** form an integrated system for assembling laser beam couplers, splitters and combiners **5** - **8**. Multiple function components, base plates **3** and mounting plates **4** can all be incorporated, producing a universal mounting kit. All components have 6 mm precision borings placed in a standardized 30 mm micro-bench layout.
Hardened steel rods **5** with super-finish surfaces are used to mount and connect the single modules. With axially mounted grub screws **6** (M3/WS 1.5 hex allen key), the rods lock the components into a solid warp-resistant unit. Spacer **7** seals the assembly from dust ingress and light egress.

B Laser beam coupler 60SMS-...
The laser beam couplers from Schäfter+Kirchhoff efficiently launch a collimated laser beam into a polarization-maintaining singlemode fiber with a mode field diameter as low as 2.5 µm.
Features include:
• Integral coupling lens, from f 2.7 to 18 mm, for highly efficient matching of beam geometries.
• Focus adjustment of integral lens **1** with positive locking by 'non-contact' grub screws **2**.
• A tilt adjustment **3** with carbide inlay for lateral positioning of the beam focus on the mode field of a singlemode fiber in the FC connector **4**.
• FC connectors with either the inclined coupling axis of the FC-APC type or the coaxial FC-PC type (optionally ST, DIN-AVIO, F-SMA) couple the singlemode fiber cable. The inclined coupling axis of the FC-APC connector prevents back-reflections into the laser beam source.
• FC connector fiber cable ferrule positively located with M1.6 grub screw.
• Tightly fitting cylinder system **5** Ø 19.5 mm with a circular V-groove (to align polarization axis) containing an O-ring (for 'non-contact' locking screws).

C Polarizer 48PM-S
• Polarisation: linear 10,000:1
• Aperture Ø 3.5 mm
• Mounted in self-locking bearing with rotatable axis
• Application: Suppression of the fractional p-polarization (approx. 5%) falsely deflected by the polarization beam splitter

D Beam Splitter 98/1 48BS-CC-PA
• Beam splitting ratio 98:1
• Aperture Ø 10 mm
• 1 mm fused silica plate
• Optimized for 45° incident angle and p-polarization
• Wedge angle of the plate: 0.33° to obviate the formation of etalons

E Photo Diode 48PD for Power Monitoring
• Si-diode or Ge-diode
• Aperture Ø 3 mm
• Electrical: BNC socket
• Mechanical: circular V-groove Ø 19.5 mm to fit adapter 48MB-19.5AC

F Polarization Beam Splitter PM 48PM-CC
Polarization beam splitter cube
• Polarization: linear
• In transmission p-polarized, extinction 10,000:1
• In reflection (90° deflection) s-polarized 20:1
• Aperture Ø 6 mm
• Splitting ratio depending on degree and state of polarization of the incoming radiation

G λ/2 Retardation Optics 48WP-CA
• Low order quartz retarders
• Aperture Ø 5 mm
• Self-locking adjustment flange
• Rotary axis inclined 3° in order to avoid back reflection and etalons
• Application: Rotating the axis of linearly polarized laser radiation

H Dichroic Beam Combiner 48BC-CC
Two laser beams of different wavelengths are combined to produce a coaxial beam with equal states of polarization
• 1mm fused silica with a wavelength-dependent coating optimized for 45° incidence
• 0.33° plate wedge angle to obviate etalon formation

I PM Fiber Cable PMC-... with inclined FC-APC Connectors
Singlemode fibers are characterized by their numerical aperture (NA), the mode field diameter (MFD) and the cut-off wavelength λ_{CT} .
• Polarization-maintaining singlemode fibers with polarization axis indicated by alignment marker
• Mode field diameter 2.5 - 10 µm
• Wavelength 370 - 1750 nm, usable spectral bandwidth typically λ_{CT} to approx. $1.3 \times \lambda_{CT}$

Atomictap_Act_ForFiberOptics_09_E.indd Page 42