

# Fiber optics for laser cooling and trapping

## Combining and collimating multiple laser beams for manipulating atoms

Over the last two decades, the interest in the investigation of atoms at ultra-low temperatures has increased substantially, as is reflected in the number of Nobel prizes awarded during this time. The major focus has shifted from primarily cooling down atoms as close as possible to absolute zero and towards the experimental investigation of these already cooled atoms. Fiber-optical components designed for the accomplishment of these goals assist researchers all over the world in concentrating their experimental effort on their endeavours with ultra-cold atoms.

Both the cooling processes and the experimental investigations themselves are highly reliant on the successful manipulation of atoms by light. The light sources must be highly complex and extremely sensitive laser systems. Furthermore, a central point of these quantum-optical experiments is a vacuum chamber in which the radiation from the laser sources has to be delivered.

A system of polarization-maintaining fiber optics provides the critical physical link between the almost industrial environment of the laser beam sources and the rarefied test environment of the vacuum chamber.

### Fiber port cluster

A widely used effective cooling and trapping method is the magneto-optical trap (MOT). A MOT requires highly frequency-stabilized, narrow width laser radiation to be launched from up to six different directions into a vacuum chamber. This can be achieved by a fully integrated and robust fiber port cluster (Figure 1).

Fiber-optic systems are much more compact and enjoy greater stability than conventional breadboard setups. The fiber-optic systems are shipped fully pre-aligned and are rugged enough for use in the most extreme environments. Some examples of hugely demanding applications include their successful use in zero-G experiments,

### THE AUTHORS

#### CHRISTIAN KNOTHE

Christian Knothe first studied Physics at the University of Freiburg i. Br. with a focus on laser spectroscopy before completing his doctoral thesis in fiber optics at the Technical University of Hamburg-Harburg. Since he joined Schäfter+Kirchhoff in 2005, he has been responsible for the advanced fiber optic applications.



Dr. Christian Knothe  
Schäfter+Kirchhoff GmbH  
Kieler Str. 212  
22525 Hamburg, Germany  
Phone: +49 (0)40 853 997 - 18  
Fax: +49 (0)40 853 997 - 79  
E-mail: Ch.Knothe@SuKHamburg.de  
Website: www.SuKHamburg.de

#### ULRICH OECHSNER

Ulrich Oechsner first studied Physics before completing his doctoral thesis at the University of Hamburg. After research activities in the fields of electro-physiology and physiological optics, he joined Schäfter+Kirchhoff in 2000 and is responsible for optical design and system development.



Dr. Ulrich Oechsner  
Schäfter+Kirchhoff GmbH  
Kieler Str. 212  
22525 Hamburg, Germany  
Phone: +49 (0)40 853 997 - 21  
Fax: +49 (0)40 853 997 - 79  
Email: U.Oechsner@SuKHamburg.de  
Website: www.SuKHamburg.de

either run on an airplane performing parabolic flights [1], or even by using a drop tower [2].

Using the fiber port cluster, the linearly polarized fiber-coupled radiation is split in polarization-maintaining fiber cables. The fiber cables contribute to a polarization maintenance of more than 26 dB (at 780 nm) and have fiber connectors of the FC-APC (angled physical contact) type for deterring back-reflections. Radiation splitting is achieved by using a cascade of rotary half-wave plates in combination with polarization beam splitters (Figure 2a). This provides a remarkable degree of flexibility and allows almost any desired splitting ratio to be set by rotating the half-wave plates (Figure 3).

A basic component in these fiber port clusters is a laser beam coupler. It is used both as input and output and collimates the fiber-coupled radiation that enters the system and launches the split radiation into the output fiber cables. Standard configurations use 3, 4 or 6 output ports. The large variety of available focal lengths and

coatings for the diffraction limited optics is largely responsible for the high coupling efficiencies of more than 60 % for the complete fiber port cluster. An integrated power monitor assists the operator during the process of launching the laser into the input fiber cable.

Fiber port clusters are also offered with two input ports for those applications, such as for a MOT for rubidium atoms, that uses a trapping and a re-pumping laser simultaneously. It is also possible to combine beams of different wavelengths at the input port of a fiber port cluster for the subsequent splitting of both components equally. In these dual-wavelength systems, laser beam couplers with achromatically or even apochromatically corrected optics are used to obtain coupling efficiencies as high as those of a monochromatic system.

For beam combinations with large wavelength differences, such as the 461 and 689 nm used in a strontium MOT, a dichroic beam combiner is used (Figure 2b). If the wavelength difference of the two lasers is too large for guiding in a common sin-

gmode fiber, there are specially developed fiber collimators with an integrated dichroic beam combiner that have two separate input connections for the two sources (see below).

If the wavelength difference is too small for a dichroic beam combiner, e.g. in the two species MOT for potassium (767 nm) and rubidium (780 nm), a polarization beam splitter with subsequent dichroic wave plate is used (Figure 2c).

### Fiber collimators

Before launching fiber-coupled radiation into a vacuum chamber, the radiation requires collimation. Fiber collimators with focal lengths from 2.7 mm up to 200 mm that produce collimated beams with diameters ranging from 0.5 mm up to 36 mm are well suited for this purpose.

By integrating a quarter-wave plate within the fiber collimator, it is possible to generate the circularly polarized beam required for MOTs. Access to the integrated quarter-wave plate for adjustment without disassembly is provided by an externally accessible gear mechanism, which drives the rotary mounted wave plate using a special key (Figure 3).

In the special case of a dipole trap, laser beams with an elliptical cross-section are required. This is achieved by fiber collimators with integrated anamorphic beam expanders. They produce beams with an elliptical aspect ratio of up to 3:1.

When using laser beam sources of different wavelengths, dichroic fiber collimators are used to combine and then expand the single common beam. These fiber collimators are also fitted with appropriate dichroic quarter-wave plates that generate circularly polarized beams for both wavelengths simultaneously. That is relevant for the demand of MOT applications.

### Polarization analyzer

In the past, a general fear of increased polarization fluctuations from optical fibers was sufficient to dissuade early adopters from replacing their bulky and unwieldy optical breadboard systems with more modern fiber-optical systems.

By using polarization-maintaining (PM) singlemode fibers with integrated stress elements, the polarization state of a linearly polarized beam is maintained. These PM fibers have two independent axes, designated as "fast" and "slow". Linear polarization is preserved when the polarization direction of the laser beam is precisely aligned with one of these axes. Disturbing influences,

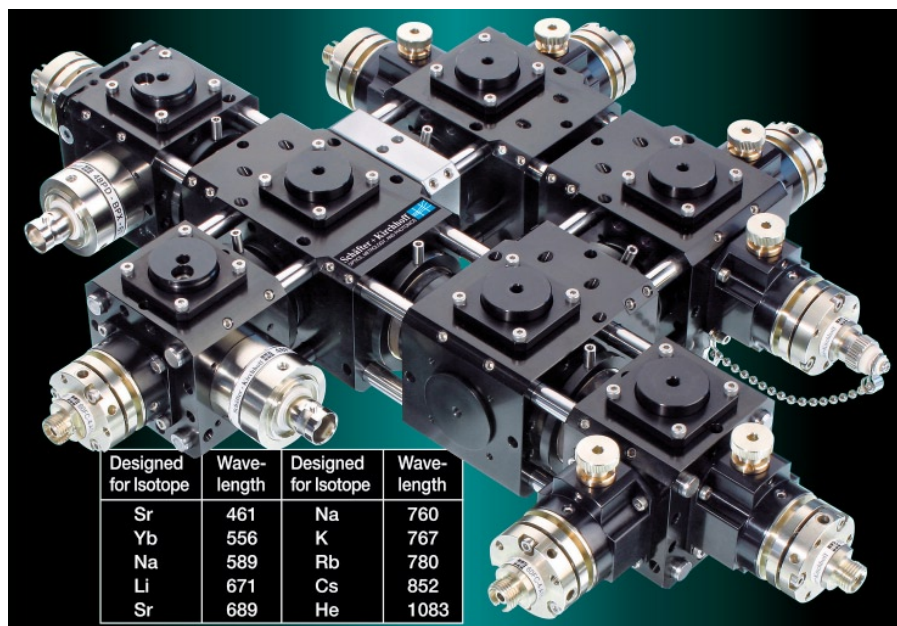

FIG. 1: The fiber port cluster is much more compact than unwieldy 1 m<sup>2</sup> breadboard constructions.

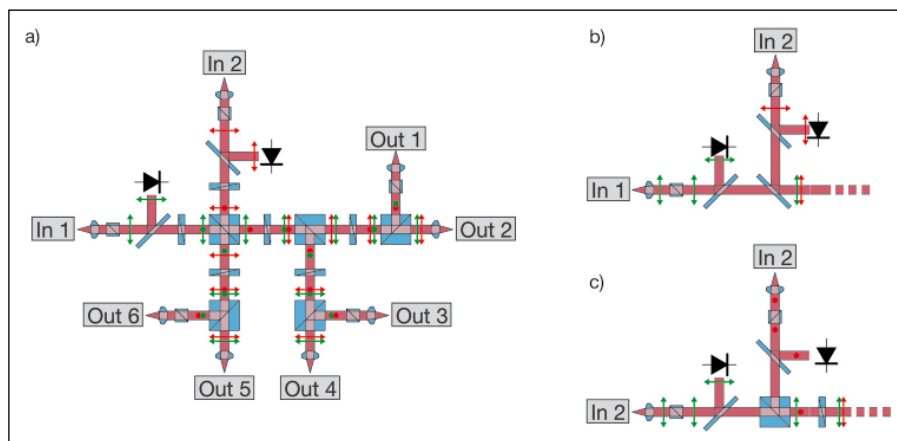

FIG. 2: a) Optical scheme of a fiber port cluster. The arrows and the dots denote the state of polarization. b) Input group (with two power monitors) for combining two wavelengths with a dichroic beam combiner, c) by means of a polarization beam combiner followed by a dichroic wave plate.

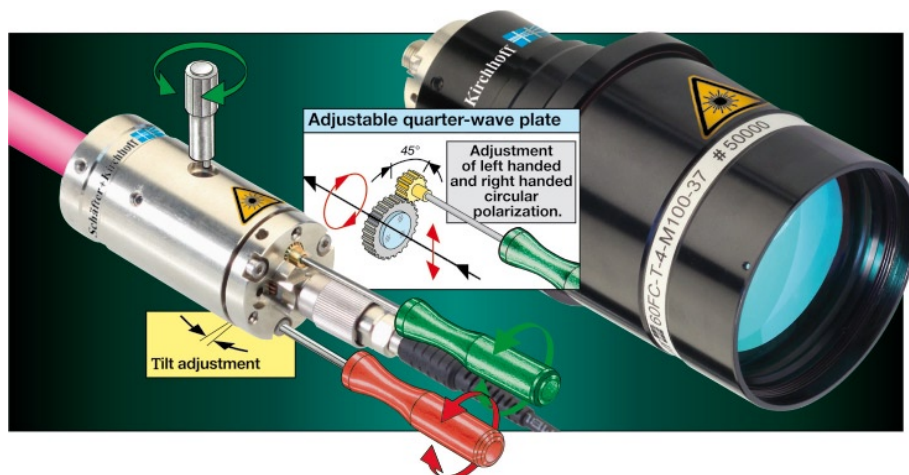

FIG. 3: Fiber collimator with integrated quarterwave plate. The wave plate is rotated by means of a gear using a special key.

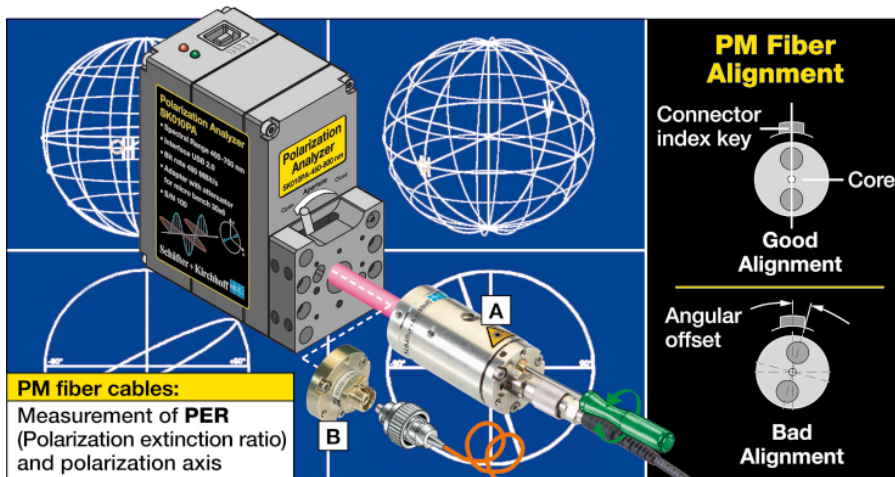

FIG. 4: Polarization analyzer with attached fiber collimator (A) or fiber adapter (B).

such as a change in temperature, vibration or bending of the fiber cable, can cause the radiation that emanates from the end of the fiber to be either unstably elliptically polarized or partially depolarized, depending on its coherence length.

In order to monitor the adjustment of the fiber and the polarization axes, polarization analyzers (Figure 4) are used. Special routines simplify the adjustment task and measure the final polarization state as well as quantifying any residual fluctuations. The analyzer measures the complete state of polarization (all Stokes parameters), which can alternatively be displayed as polarization ellipse, or as a point on the Poincaré

sphere [3]. Thereby, a rapid and reproducibly precise alignment of the fiber is possible. Analyzers are available in various versions covering the full wavelength range of 350–1600 nm.

Polarization analyzers are also used for free space beams, such as for the alignment and quantification of the quarter-wave plate adjustments in fiber collimators (Figure 4) or for cooling methods in quantum optics that require a circularly polarized beam with a defined rotation.

#### References

- [1] G. Varoquaux et al. I.C.E.: "An ultra-cold atom source for long-baseline interferometric inertial sensors in reduced gravity", ArXiv: 0705.2922 (2007)
- [2] T. Könnemann et al.: "A freely falling magneto-optical trap drop tower experiment", Applied Physics B: Lasers and Optics 89 (4), 431 (2007)
- [3] D. S. Kliger, J. W. Lewis, C. Eimerz Randall: "Polarized Light in Optics and Spectroscopy", Elsevier, Oxford (1990)

#### THE COMPANY

##### Schäfer+Kirchhoff

Hamburg, Germany

Schäfer+Kirchhoff has accumulated over 40 years of experience in the development of opto-mechanical and opto-electronic systems for use in research, aviation and in space, as well as for demanding medical and industrial applications. For more than 20 years, Schäfer+Kirchhoff has also designed and manufactured their own CCD line scan camera systems, laser sources and beam-shaping optics for supply worldwide. Besides polarization-maintaining fiber cables, laser beam couplers and fiber collimators, Schäfer+Kirchhoff also offers fiber-optical systems specifically developed to satisfy the subtle demands of highly discriminating quantum-optic experiments.

[www.SuKHamburg.de](http://www.SuKHamburg.de)